

PRODN[®]

INTELLIGENT INVERTER WATER PUMP

PRODN[®]



PRODN INTELLIGENT PUMP (ANHUI) CO.,LTD.

 No. 1128, Nanchiyi Road, Anhui Xinwu Economic Development Zone, Wanzhi District, Wuhu City, Anhui Province, China

 prodn@prodnump.com

 www.prodnump.com

duyar
motorpompa[®]
www.duyarpump.com

2025



COMPANY FULL NAME	PRODN INTELLIGENT PUMP (ANHUI) CO.,LTD.
FACTORY ADDRESS	No. 1128, Nanchiyi Road, Anhui Xinwu Economic Development Zone, Wanzhi District, Wuhu City, Anhui Province, China
DATE OF ESTABLISHMENT	Established in 2016, the company evolved from its predecessor, PRODN INTELLIGENT CONTROL ELECTRONIC TECHNOLOGY (ZHEJIANG) CO.,LTD.
PROFILE	Intelligence and energy saving are the major trends in the development of water pumps. PRODN is a pioneer in the intelligent inverter water pump industry and a technology enterprise specializing in the design, research, and manufacturing of smart pumps. Our corporate goal is to offer customers more energy-efficient, smarter, and more convenient water pumps that are also highly cost-effective through technological innovation.
COMPANY CERTIFICATION	National High-tech Enterprise / National Sci-tech SME (Science and Technology-based Small and Medium Enterprise) / Provincial Innovative Enterprise / Provincial Specialized, Refined, Unique, and New Enterprise / High-Growth Enterprise ISO9001 / ISO14001 / ISO45001 CE / RED / ETL / WATERMARK / NSF
Core Technologies	Specialized in R&D, design, production, and sales of permanent magnet motors, permanent magnet variable frequency drivers, and integrated temperature-pressure sensors.
Technical Patents	10+ invention patents, 40+ utility model patents, 80+ design patents and 10+ independent software copyrights
UNIT Q'TY / YEAR	1000000
Total Area	71300 m ²
Area of Structure	35000 m ²

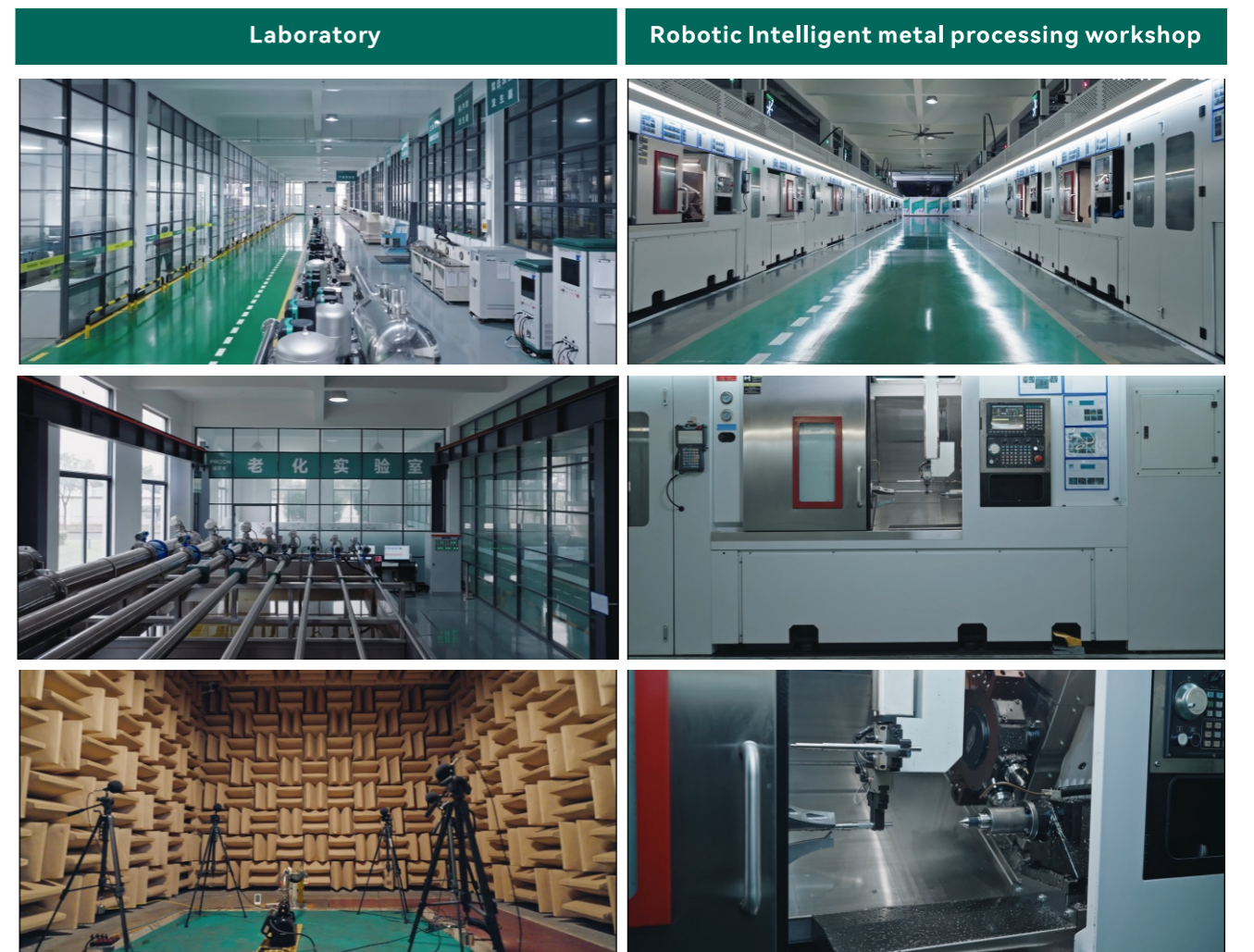

INDEPENDENTLY DEVELOP
CORE TECHNOLOGIES



Pressure Sensor workshop



Variable Frequency
controller workshop

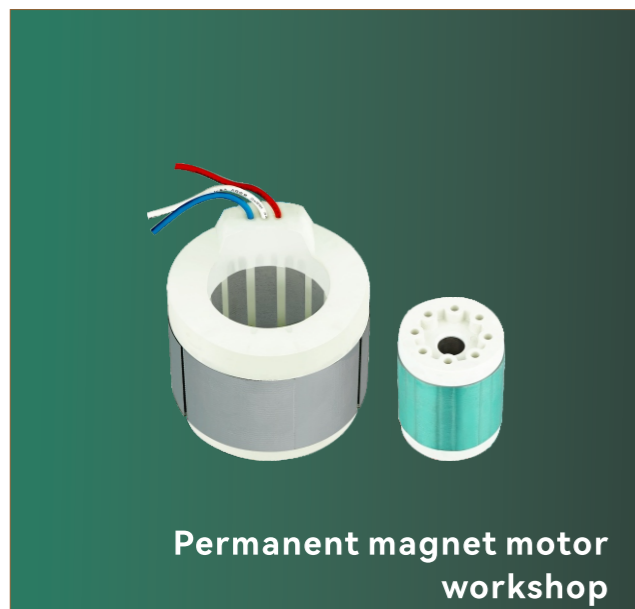

Permanent magnet motor
workshop

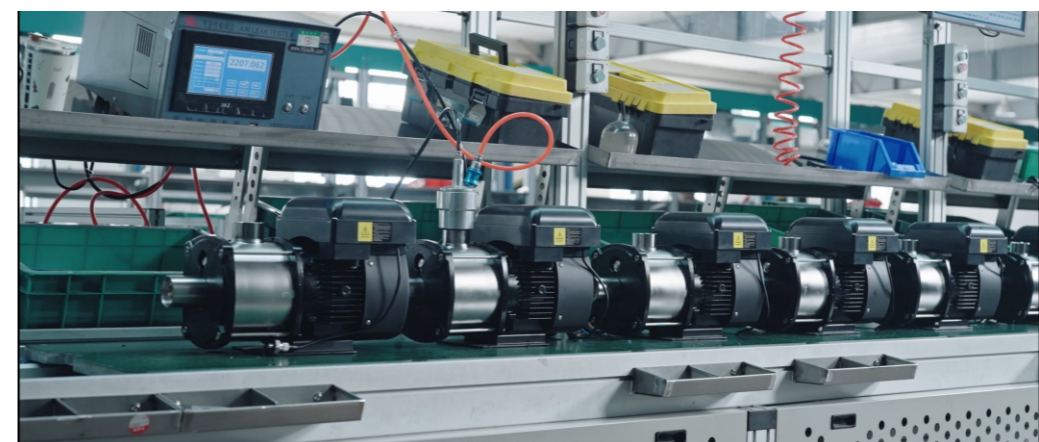
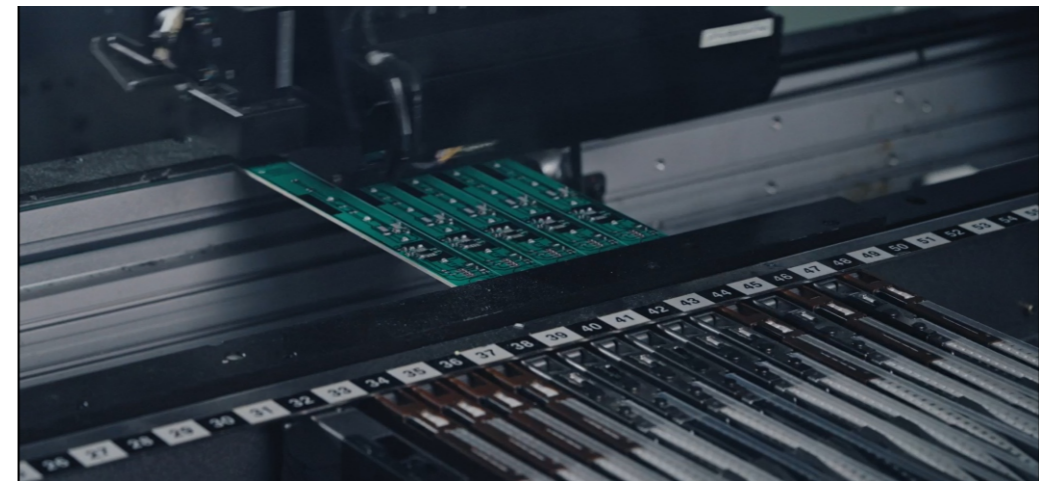

SMT processing workshop

Assembly workshop

PRODN[®]



H

Multi-stage Centrifugal Pump



Features

- Energy conservation
- Permanent magnet motor
- Constant pressure
- Low noise
- Multi-protection
- Wide voltage
- Frost protection
- Compact and lightweight
- Integral integration
- Double water outlet
- APP function(option)
- Parallel function(option)
- Food grade overflow parts (option)
- Self-priming(option)

Model Instruction

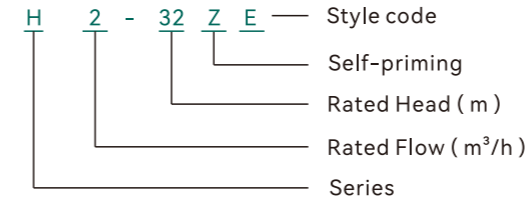

Whole-house water pressure boosting for residential use



Working Conditions

pH Value	5-8
Ambient temperature	0-40°C
Ambient humidity	Max.85% (RH)
Medium temperature	0-60°C(The maximum temperature of liquid not over than 75°C)

Performance Data

Model	H2-20ER1	H2-32ER1	H3-50ER1	H2-32R1	H3-50R1
Power(W)	370	550	1100	550	1100
Max.Q(m³/h)	4.1	4.2	5.5	4.2	5.5
Rated.Q(m³/h)	2.0	2.0	3.0	2.0	3.0
Max.H(m)	32	42	65	42	65
Rated.H(m)	20	32	50	32	50
Speed(r/min)	6000	4800	6200	4800	6200
Current(A)	1.7	3.7	5.3	3.7	5.3
Voltage(V)	220	220	220	220/127	220
Frequency(Hz)	50/60	50/60	50/60	50/60	50/60
Self-priming Head(m)	/	/	/	/	/
Inlet(mm)	25	25	25	25	25
Outlet(mm)	25	25	25	25	25
Multi-Pump	×	×	×	●	●
WiFi	×	×	×	●	●

Model	H8-30R1	H8-45R1	H2-32Z	H3-40Z
Power(W)	1500	2200	550	750
Max.Q(m³/h)	12	14	5.5	7.0
Rated.Q(m³/h)	8.0	8.0	2.0	3.0
Max.H(m)	42	62	46	48
Rated.H(m)	30	45	32	40
Speed(r/min)	4000	4800	4000	4000
Current(A)	6.2	9.6	3.5	6.2
Voltage(V)	220	220	220	220
Frequency(Hz)	50/60	50/60	50/60	50/60
Self-priming Head(m)	/	/	7.5	7.5
Inlet(mm)	40	50	25	25
Outlet(mm)	40	50	25	25
Multi-Pump	●	●	●	●
WiFi	●	●	●	●

Installation Dimensions

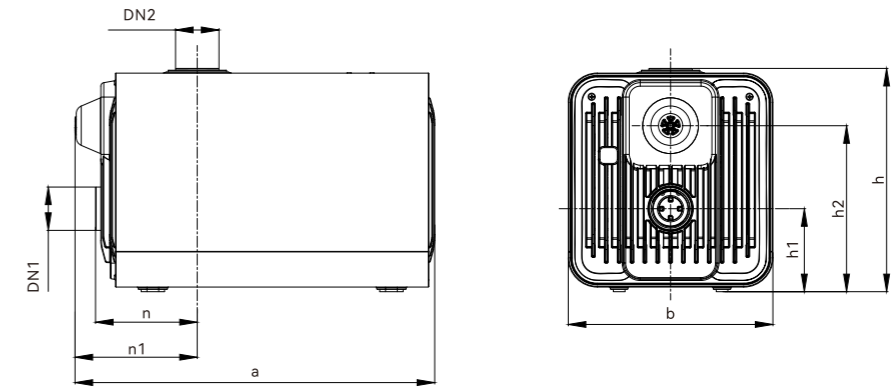

Model	DN1	DN2	Installation dimension (mm)							N.W. (kg)	G.W. (kg)	Carton size (mm)
			a	b	h	h1	h2	n	n1			
H2-20E	G1	G1	308	175	201	71	142	87	104	5.0	5.6	363x224x230

Performance Curve

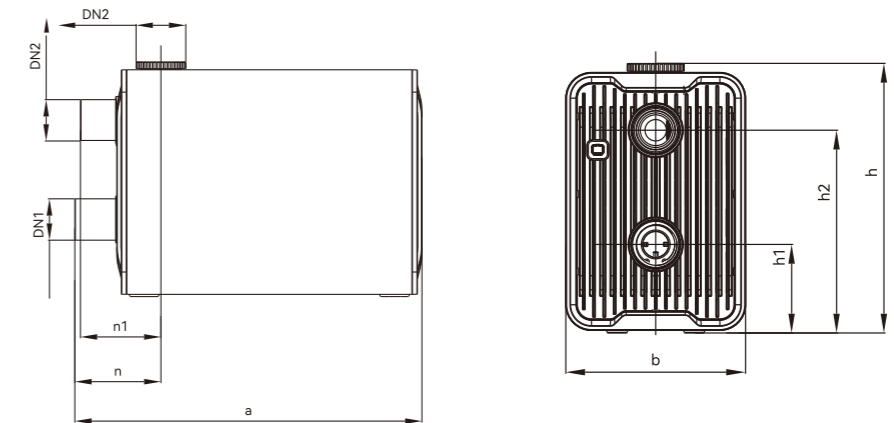
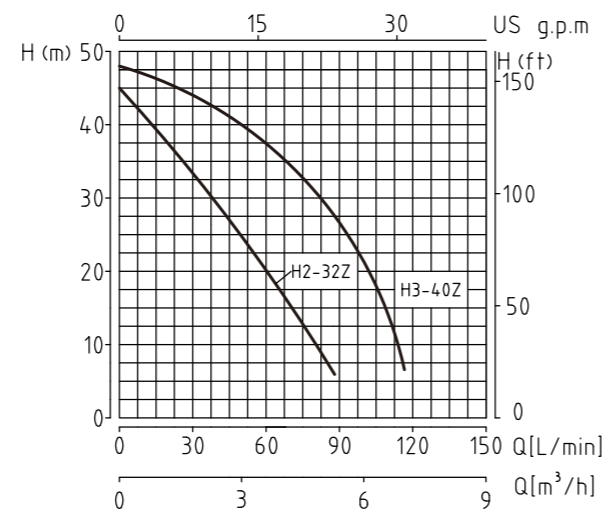
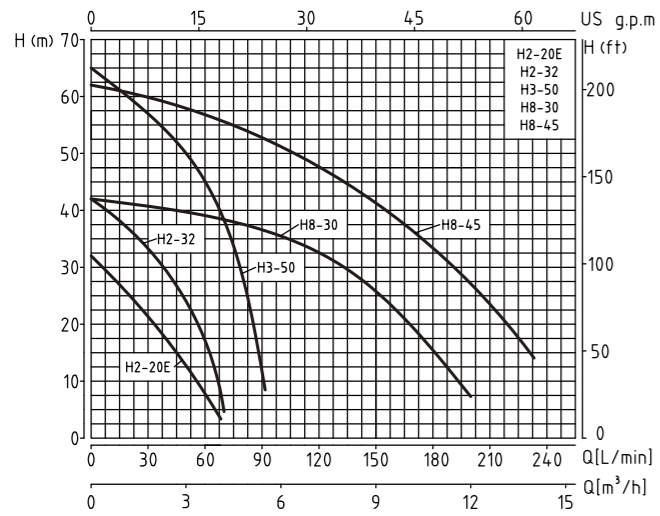

Model	DN1	DN2	Dimensions (mm)							N.W. (kg)	G.W. (kg)	Carton size (mm)
			a	b	h	h1	h2	n	n1			
H2-32E	G1	G1	311	140	212	71	160	77	72	5.8	6.3	365x185x250
H3-50E	G1	G1	311	140	212	71	160	77	72	5.8	6.3	365x185x250
H2-32	G1	G1	311	140	212	71	160	77	72	5.8	6.3	365x185x250
H3-50	G1	G1	311	140	212	71	160	77	72	5.8	6.3	365x185x250
H2-32Z	G1	G1	408	180	258	92	196	101	101	8.2	9.0	490x240x313
H3-40Z	G1	G1	408	180	258	92	196	101	101	8.7	9.5	490x240x313
H8-30	G1 ½	G1 ½	404	169	278	82	199	107	107	11	11.8	455x220x320
H8-45	G2	G2	404	169	278	82	199	107	107	12	12.8	455x220x320

CHM2-4ZH(E)

Self-priming Multi-stage Centrifugal Pump

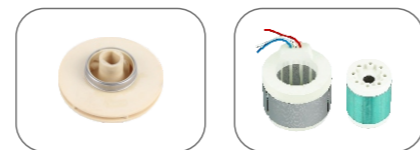

Features

- Energy conservation
- Permanent magnet motor
- Constant pressure
- Low noise
- Multi-protection
- Wide voltage
- Frost protection
- Compact and lightweight
- Integral integration
- Double water outlet
- APP function
- Timing mode
- Self-priming

Model Instruction

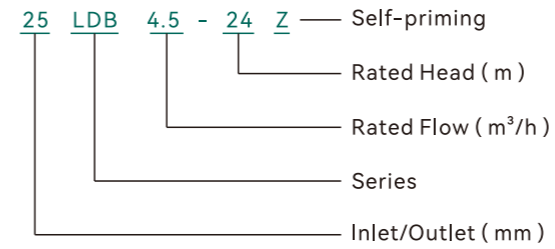

Whole-house water pressure boosting for residential use



Working Conditions

pH Value	5-8
Ambient temperature	0-40°C
Ambient humidity	Max.85% (RH)
Medium temperature	0-60°C(The maximum temperature of liquid not over than 75°C)

Performance Data

Model	CHM2-4ZH	CHM2-4ZHE
Power(W)	750	750
Max.Q(m³/h)	6.0	6.0
Rated.Q(m³/h)	2.0	2.0
Max.H(m)	45	45
Rated.H(m)	41	41
Speed(r/min)	6000	4800
Current(A)	4.8	4.9
Voltage(V)	220	220
Frequency(Hz)	50/60	50/60
Self-priming Head(m)	7.5	7.5
Inlet(mm)	25	25
Outlet(mm)	25	25
WiFi	●	●

Performance Curve

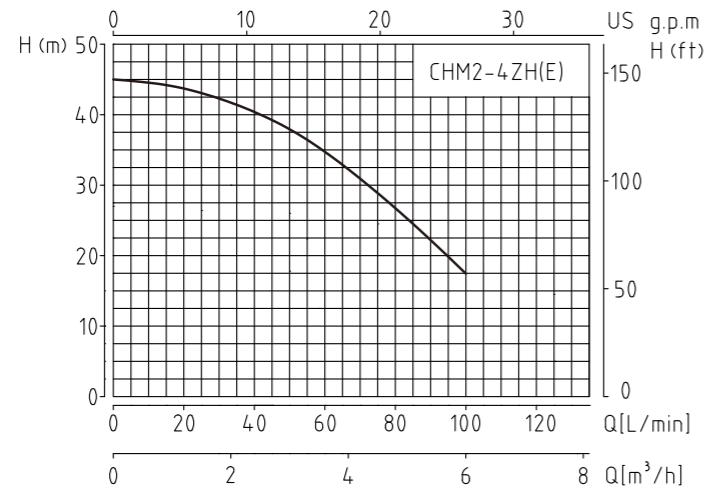

Installation Dimensions

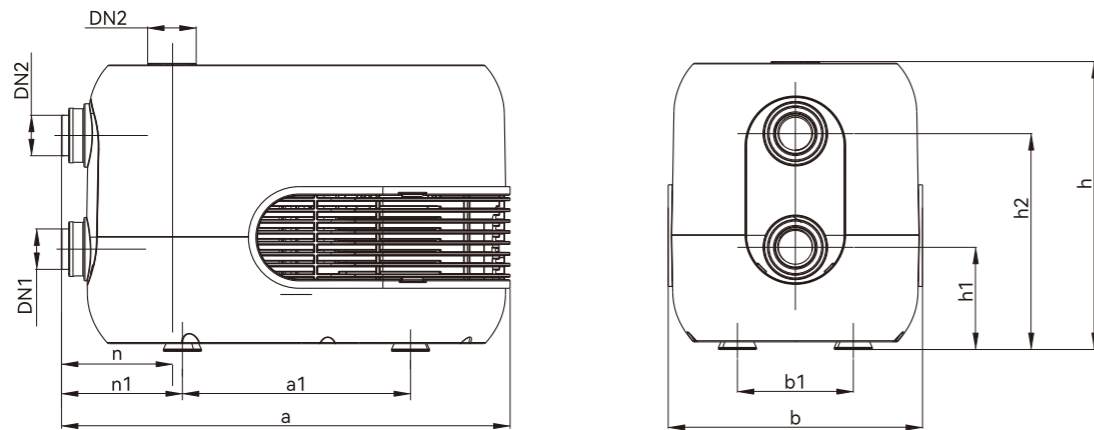

Model	DN1	DN2	Dimensions (mm)									N.W. (kg)	G.W. (kg)	Carton size (mm)
			a	a1	b	b1	h	h1	h2	n	n1			
CHM2-4ZH	G1	G1	410	209	233	106	264	94	198	102	111	10.5	11.3	458x285x309
CHM2-4ZHE	G1	G1	410	209	233	106	264	94	198	102	111	10.5	11.3	458x285x309

CHM4-2H

Multi-stage Centrifugal Pump

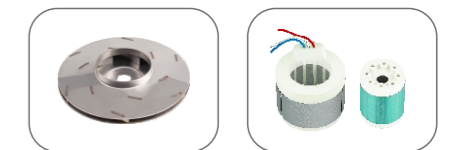

Features

- Energy conservation
- Permanent magnet motor
- Constant pressure
- Low noise
- Multi-protection
- Wide voltage
- Frost protection
- Compact and lightweight
- Integral integration
- APP function
- Timing mode
- Food grade overflow parts (option)

Model Instruction

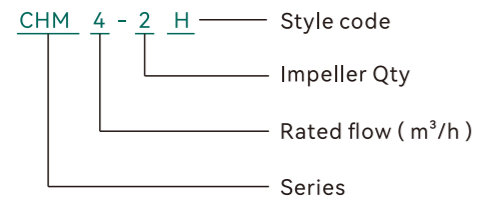

Whole-house water pressure boosting for residential use



Working Conditions

pH Value	5-8
Ambient temperature	0-40°C
Ambient humidity	Max.85% (RH)
Medium temperature	0-60°C(The maximum temperature of liquid not over than 75°C)

Performance Data

Model	CHM4-2H
Power(W)	750
Max.Q(m ³ /h)	8.0
Rated.Q(m ³ /h)	4.0
Max.H(m)	37
Rated.H(m)	30
Speed(r/min)	4000
Current(A)	6.0
Voltage(V)	220/127
Frequency(Hz)	50/60
Self-priming Head(m)	/
Inlet(mm)	32
Outlet(mm)	25
WiFi	●

Performance Curve

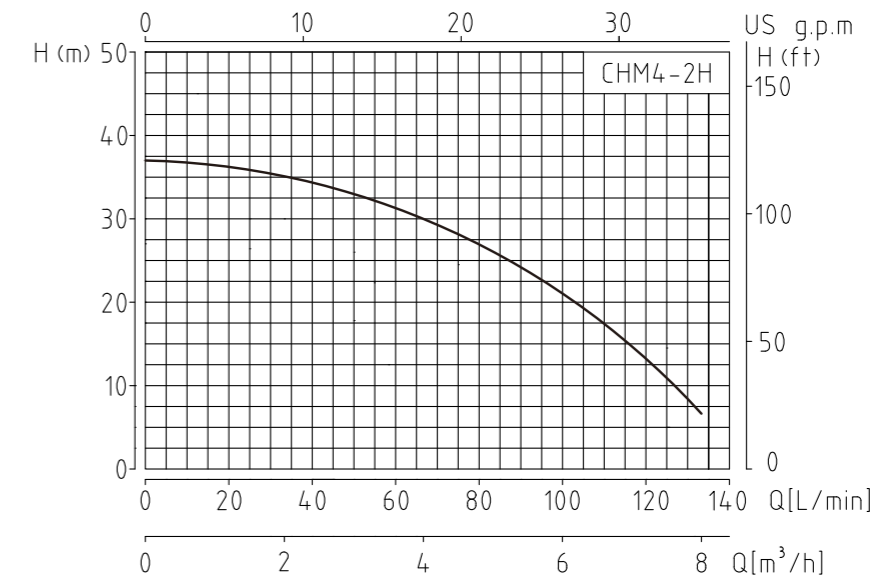

Installation Dimensions

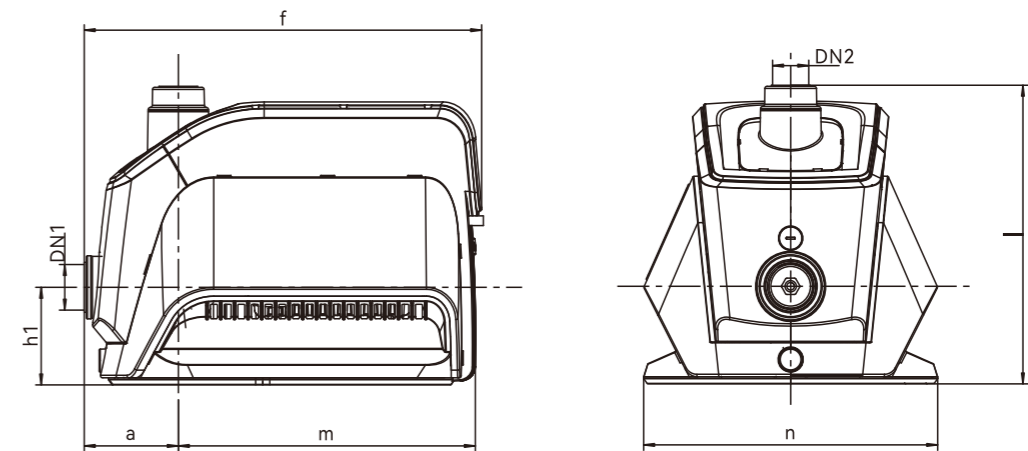

Model	DN1	DN2	Dimensions (mm)						N.W. (kg)	G.W. (kg)	Carton size (mm)
			a	f	h1	l	m	n			
CHM4-2H	G1¼	G1	86.5	366	90	275	273	271	10	10.8	428x328x312

LDB-Z

Self-priming Centrifugal Pump

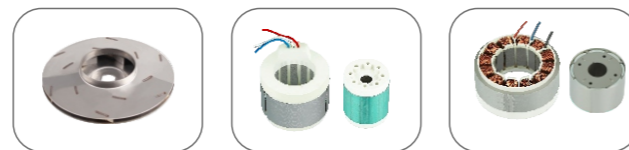

Features

- Energy conservation
- Permanent magnet motor
- Constant pressure
- Low noise
- Multi-protection
- Wide voltage
- Frost protection
- Compact and lightweight
- Integral integration
- APP function
- Timing mode
- Self-priming

Model Instruction

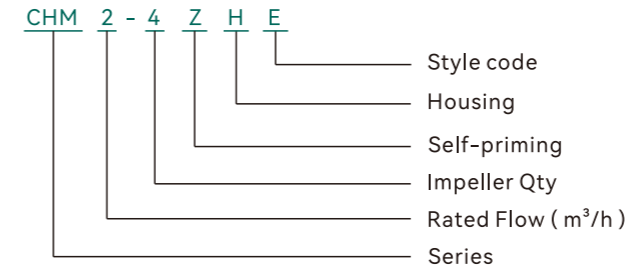

Whole-house water pressure boosting for residential use



Working Conditions

pH Value	5-8
Ambient temperature	0-40°C
Ambient humidity	Max.85% (RH)
Medium temperature	0-60°C(The maximum temperature of liquid not over than 75°C)

Performance Data

Model	25LDB4.5-24Z	32LDB6.5-20Z
Power(W)	900	1100
Max.Q(m ³ /h)	7.5	9.5
Rated.Q(m ³ /h)	4.5	6.5
Max.H(m)	30	30
Rated.H(m)	24	20
Speed(r/min)	4000	4000
Current(A)	6.2	6.3
Voltage(V)	220	220/127
Frequency(Hz)	50/60	50/60
Self-priming Head(m)	5	5
Inlet(mm)	25	32
Outlet(mm)	25	32
WiFi	●	●

Performance Curve

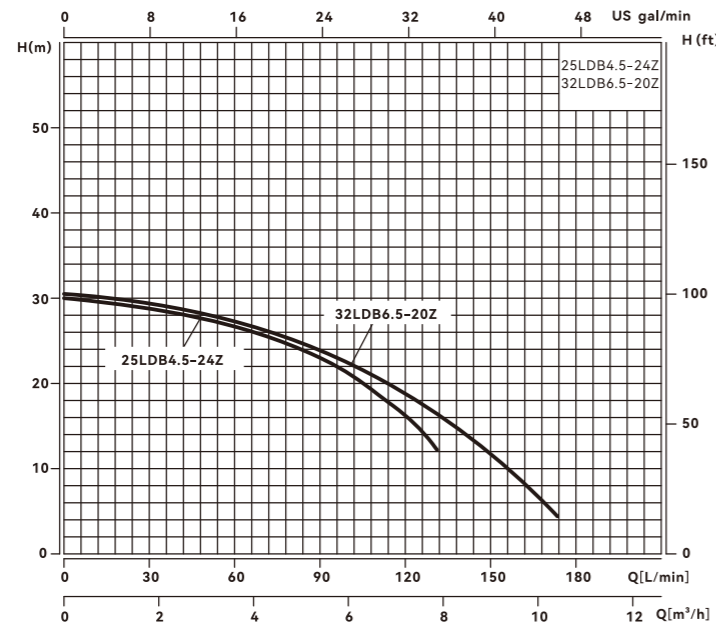

Installation Dimensions

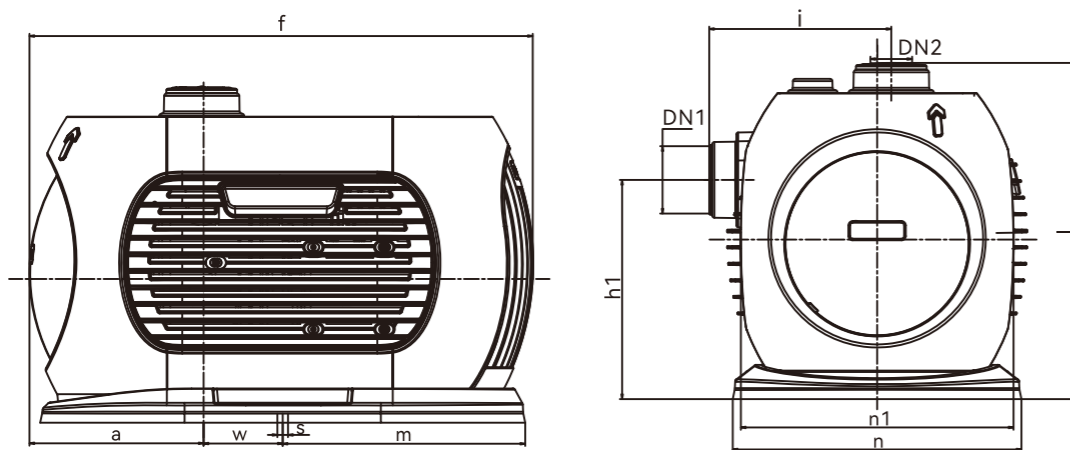

Model	DN1	DN2	Dimensions (mm)										N.W. (kg)	G.W. (kg)	Carton size (mm)
			a	f	h1	i	l	m	n	n1	w	s			
25LDB4.5-24Z	G1	G1	146	426	185.5	147	284.5	205	244	228	68.5	9	15.8	16.9	480x305x345
32LDB6.5-20Z	G1½	G1½	146	426	185.5	147	284.5	205	244	228	68.5	9	15.8	16.9	480x305x345

LDB-SM

Intelligent Inverter Booster Pump



Features

- ⊙ Energy conservation
- ⊙ Permanent magnet motor
- ⊙ Constant pressure
- ⊙ Low noise
- ⊙ Multi-protection
- ⊙ Wide voltage
- ⊙ Frost protection
- ⊙ Compact and lightweight
- ⊙ Integral integration
- ⊙ APP function(option)
- ⊙ Food grade overflow parts (option)

Model Instruction

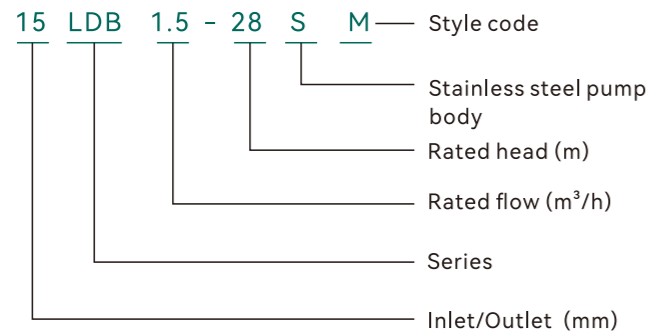

Whole-house water pressure boosting for residential use



Working Conditions

pH Value	5-8
Ambient temperature	0-40°C
Ambient humidity	Max.85% (RH)
Medium temperature	0-60°C(The maximum temperature of liquid not over than 75°C)

Performance Data

Model	15LDB1.5-28SM	25LDB2-25SM
Power(W)	300	300
Max.Q(m³/h)	3.6	3.6
Rated.Q(m³/h)	1.5	2.0
Max.H(m)	32	32
Rated.H(m)	28	25
Speed(r/min)	7440	7440
Current(A)	2.0	2.0
Voltage(V)	220	220
Frequency(Hz)	50/60	50/60
Self-priming Head(m)	/	/
Inlet(mm)	15	25
Outlet(mm)	15	25
WiFi	Option	Option

Performance Curve

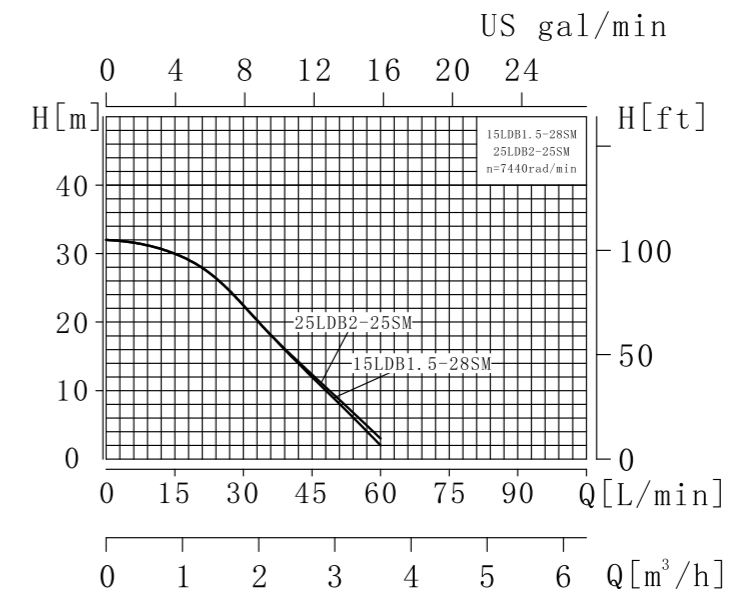

Installation Dimensions

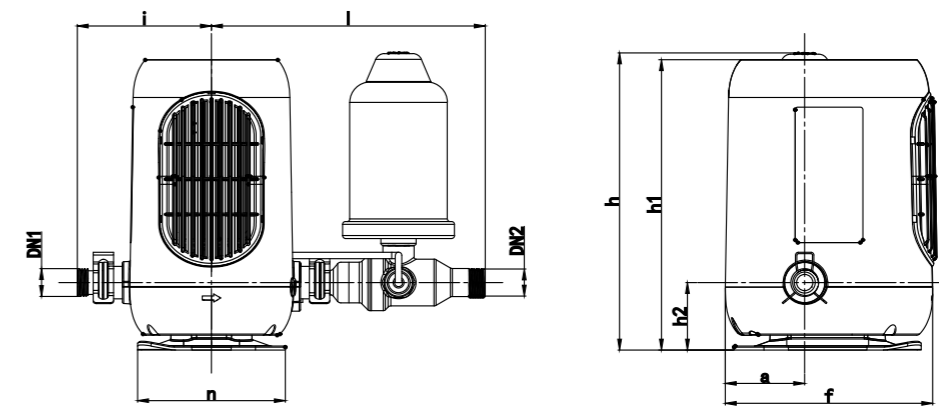

Model	DN1	DN2	Dimensions (mm)								N.W. (kg)	G.W. (kg)	Carton size (mm)
			a	f	h	h1	h2	i	l	n			
15LDB1.5-28SM	G½	G½	58.5	153	219	214	51	99	202.5	109	3.6	4.3	306x275x220
25LDB2-25SM	G1	G1	58.5	153	219	214	51	80	217	109	4.0	4.7	306x275x220

DIC

Multi-stage Centrifugal Pump

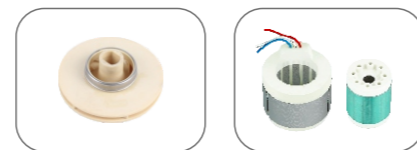

Features

- ⊙ Energy conservation
- ⊙ Permanent magnet motor
- ⊙ Constant pressure
- ⊙ Low noise
- ⊙ Multi-protection
- ⊙ Wide voltage
- ⊙ Frost protection
- ⊙ Compact and lightweight
- ⊙ Integral integration

Model Instruction

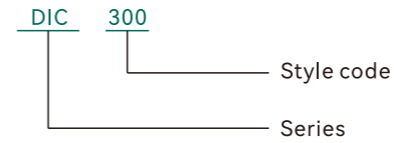

Whole-house water pressure boosting for residential use



Working Conditions

pH Value	5-8
Ambient temperature	0-40°C
Ambient humidity	Max.85% (RH)
Medium temperature	0-60°C(The maximum temperature of liquid not over than 75°C)

Performance Data

Model	DIC300	DIC800	DIC900
Power(W)	370	550	750
Max.Q(m³/h)	4.0	4.5	4.5
Max.H(m)	30	35	40
Speed(r/min)	4800	4200	4500
Current(A)	2.5	3.3	4.7
Voltage(V)	220/110	220/110	220/110
Frequency(Hz)	50/60	50/60	50/60
Self-priming Head(m)	/	/	/
Inlet(mm)	25	25	25
Outlet(mm)	25	25	25

Performance Curve

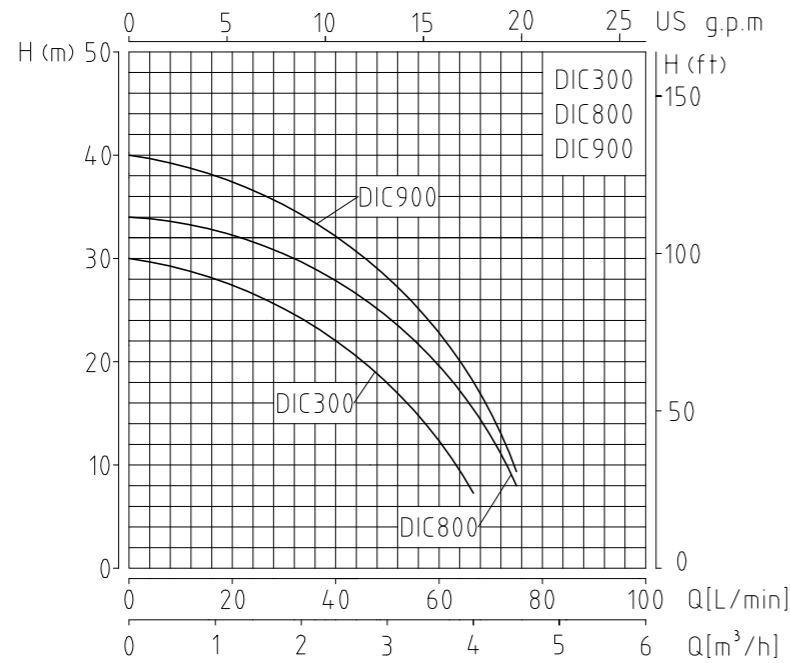

Installation Dimensions

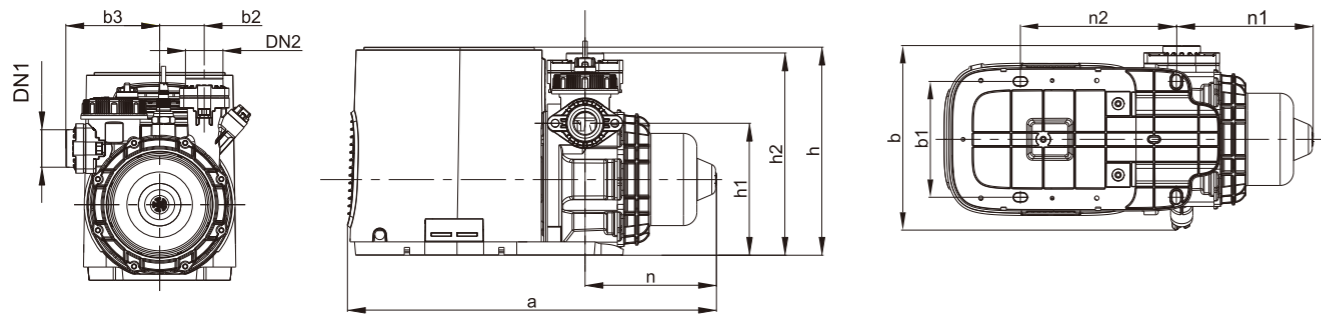

Model	DN1	DN2	Dimensions (mm)											Carton size (mm)
			a	b	b1	b2	b3	n	n1	n2	h	h1	h2	
DIC300	25	25	414	205.5	130	50	105	147.5	153.5	175	233.5	148	227	493x253x295
DIC800	25	25	440.5	205.5	130	50	105	174	180	175	233.5	148	227	493x253x295
DIC900	25	25	440.5	205.5	130	50	105	174	180	175	233.5	148	227	493x253x295

WZB-DC

Self-priming Peripheral Pump



WZB-DC



WHB-P



WZB-DCR



Features

- ⊙ Energy conservation
- ⊙ Permanent magnet motor
- ⊙ Constant pressure
- ⊙ Low noise
- ⊙ Multi-protection
- ⊙ Wide voltage
- ⊙ Frost protection
- ⊙ Compact and lightweight
- ⊙ Self-priming
- ⊙ Antirust function

Model Instruction

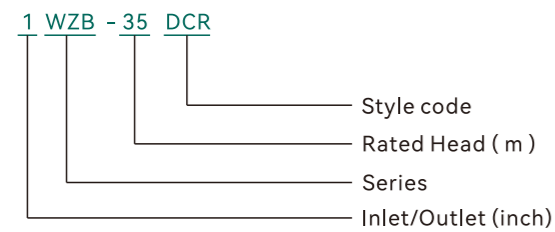
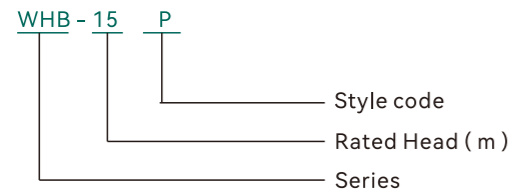
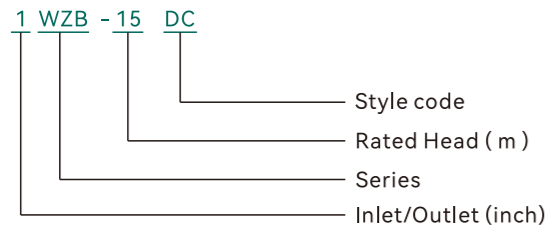

Whole-house water pressure boosting for residential use



Working Conditions

pH Value	5-8
Ambient temperature	0-40°C
Ambient humidity	Max.85% (RH)
Medium temperature	0-60°C(The maximum temperature of liquid not over than 75°C)

Performance Data

Model	1WZB-15DC	1WZB-21DC	1WZB-26DC	1WZB-36DC	1.5WZB-46DC
Power(W)	250	300	600	900	1500
Max.Q(m³/h)	1.8	2.0	3.1	4.5	5.5
Rated.Q(m³/h)	1.0	1.0	1.5	2.0	3.0
Max.H(m)	30	34	40	43	57
Rated.H(m)	15	21	26	36	46
Speed(r/min)	3000	3300	3000	4000	4000
Current(A)	1.2	1.5	3.5	4.5	5.8
Voltage(V)	220/110	220/110	220/110	220/110	220
Frequency(Hz)	50/60	50/60	50/60	50/60	50/60
Self-priming Head(m)	6	6	8	8	8
Inlet(mm)	25	25	25	25	40
Outlet(mm)	25	25	25	25	40

Model	WZB-15P	WZB-20P	WZB-25P	WZB-35P	WZB-45P
Power(W)	250	300	600	900	1500
Max.Q(m³/h)	1.8	2.0	3.1	4.5	5.5
Rated.Q(m³/h)	1.0	1.0	1.5	2.0	3.0
Max.H(m)	30	34	40	43	57
Rated.H(m)	15	20	25	35	45
Speed(r/min)	3000	3300	3000	4000	4000
Current(A)	1.2	1.5	3.5	4.5	5.8
Voltage(V)	220/110	220/110	220/110	220/110	220
Frequency(Hz)	50/60	50/60	50/60	50/60	50/60
Self-priming Head(m)	6	6	8	8	8
Inlet(mm)	25	25	25	25	40
Outlet(mm)	25	25	25	25	40

Model	1WZB-20DCR	1WZB-25DCR	1WZB-35DCR	1.5WZB-45DCR
Power(W)	300	600	900	1500
Max.Q(m³/h)	2.1	2.6	4.5	5.5
Rated.Q(m³/h)	1.0	1.5	2.0	3.0
Max.H(m)	33	45	43	57
Rated.H(m)	20	25	35	45
Speed(r/min)	3000	3500	4000	4000
Current(A)	1.8	3.7	3.5	5.8
Voltage(V)	220	220	220	220
Frequency(Hz)	50/60	50/60	50/60	50/60
Self-priming Head(m)	8	8	8	8
Inlet(mm)	25	25	25	40
Outlet(mm)	25	25	25	40

Performance Curve

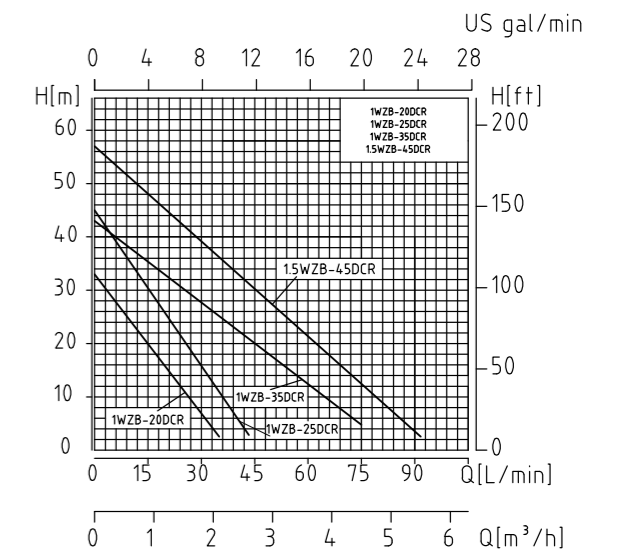
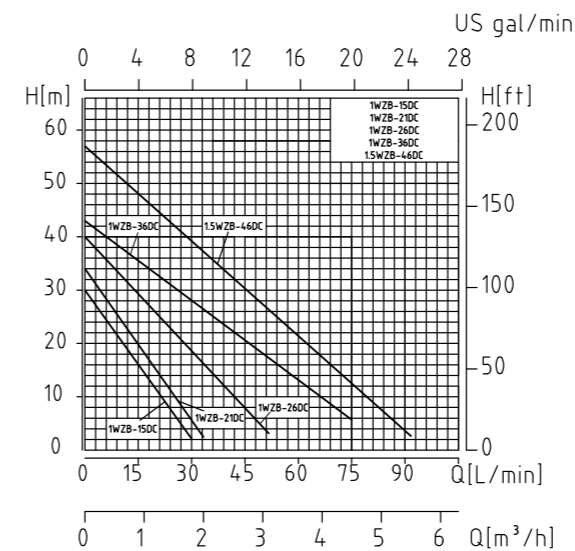

Installation Dimensions

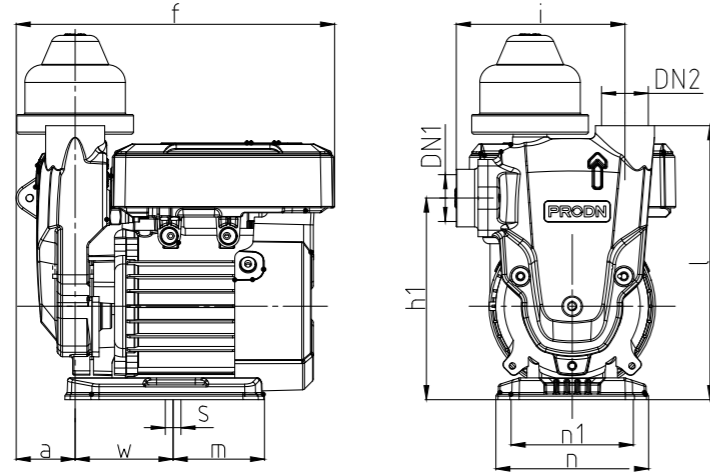

Model	DN1	DN2	Dimensions (mm)										N.W. (kg)	G.W. (kg)	Carton size (mm)
			a	f	h1	i	l	m	n	n1	w	s			
1WZB-15DC	G1	G1	42	227	144	120	195	65	109	87	70	12	6.0	6.4	265x200x300
1WZB-21DC	G1	G1	42	227	144	120	195	65	109	87	70	12	6.0	6.4	265x200x300
1WZB-26DC	G1	G1	42	232	148	131	215	65	109	87	77	12	7.3	8.0	275x205x326
1WZB-36DC	G1	G1	42	232	148	132	227	65	109	87	77	12	7.0	7.7	275x205x326
1.5WZB-46DC	G1½	G1½	54	280	165	139	243	86	139	117	81	12	9.8	10.5	320x240x350

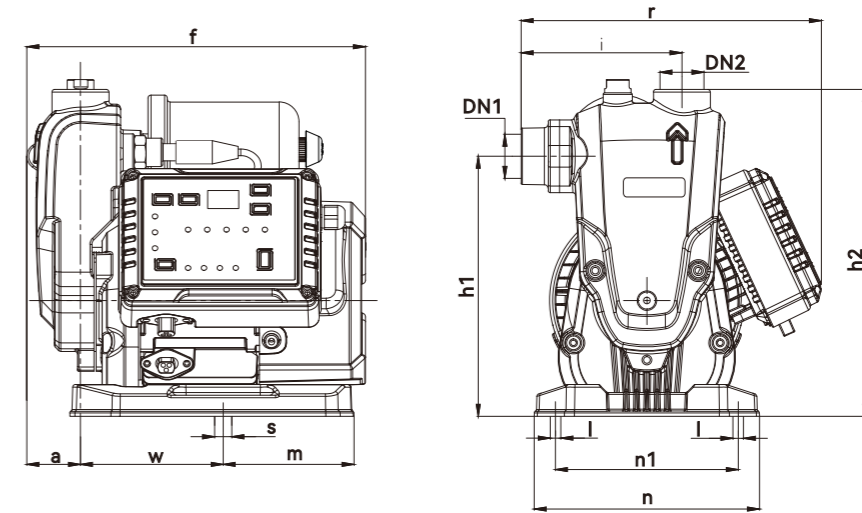

Model	DN1	DN2	Dimensions (mm)												N.W. (kg)	G.W. (kg)	Carton size (mm)
			a	f	h1	i	h2	m	n	n1	w	s	l	r			
1WZB-20DCR	G1	G1	40.5	250.8	187.5	119	237	98.8	170.1	138	104.6	13	8	228	7.8	8.5	312x237x310
1WZB-25DCR	G1	G1	40.5	250.8	187.5	119	237	98.8	170.1	138	104.6	13	8	228	8.1	8.8	312x237x310
1WZB-35DCR	G1	G1	40.5	255.7	196.5	121.5	247	98.8	170.1	138	107.8	13	8	226.8	9.1	9.7	322x237x310
1.5WZB-45DCR	G1½	G1½	53.5	267	206.5	132	257	98.8	170.1	138	106	13	8	243.7	11.8	12.5	325x275x355

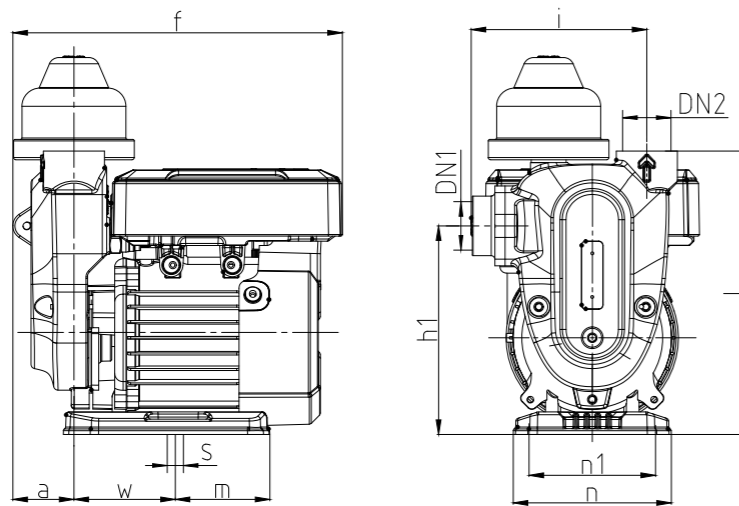

Model	DN1	DN2	Dimensions (mm)										N.W. (kg)	G.W. (kg)	Carton size (mm)
			a	f	h1	i	l	m	n	n1	w	s			
WHB-15P	G1	G1	42	227	144	120	195	65	109	87	70	12	6.0	6.4	265x200x300
WHB-20P	G1	G1	42	227	144	120	195	65	109	87	70	12	6.0	6.4	265x200x300
WHB-25P	G1	G1	42	232	148	130	215	65	109	87	77	12	7.4	8.1	275x205x326
WHB-35P	G1	G1	42	232	148	130	227	65	109	87	77	12	7.1	7.8	275x205x326
WHB-45P	G1½	G1½	54	280	165	143	243	86	139	117	81	12	9.9	10.6	320x240x350

PRODN-DC

Self-priming Peripheral Pump

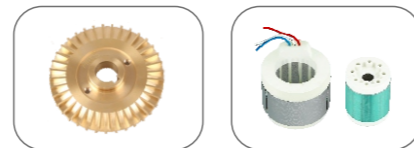

Features

- ⦿ Energy conservation
- ⦿ Permanent magnet motor
- ⦿ Constant pressure
- ⦿ Low noise
- ⦿ Multi-protection
- ⦿ Wide voltage
- ⦿ Frost protection
- ⦿ Compact and lightweight
- ⦿ Self-priming
- ⦿ Antirust function

Model Instruction

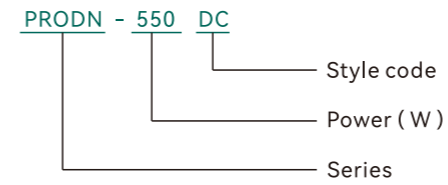

Whole-house water pressure boosting for residential use



Working Conditions

pH Value	5-8
Ambient temperature	0-40°C
Ambient humidity	Max.85% (RH)
Medium temperature	0-60°C(The maximum temperature of liquid not over than 75°C)

Performance Data

Model	PRODN-550DC	PRODN-900DC
Power(W)	550	900
Max.Q(m³/h)	3.0	3.9
Rated.Q(m³/h)	1.5	1.5
Max.H(m)	40	45
Rated.H(m)	24	30
Speed(r/min)	3000	3000
Current(A)	3.6	5.5
Voltage(V)	220	220
Frequency(Hz)	50/60	50/60
Self-priming Head(m)	8	8
Inlet(mm)	25	32
Outlet(mm)	25	32

Performance Curve

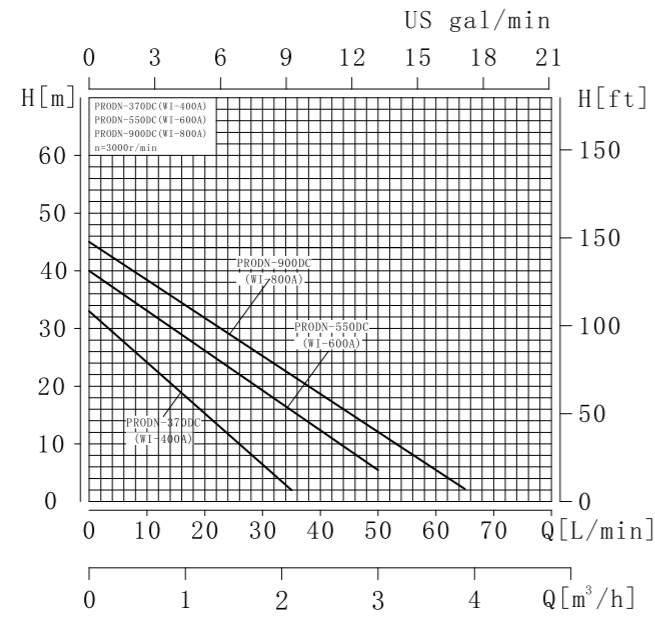

Installation Dimensions

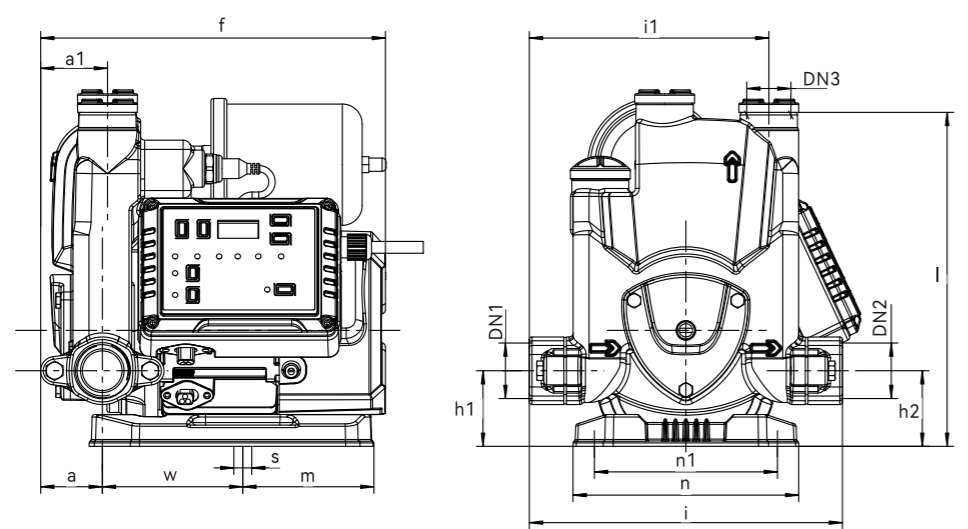

Model	DN1	DN2	DN3	Dimensions (mm)														N.W. (kg)	G.W. (kg)	Carton size (mm)
				a	a1	f	h1	h2	i	i1	l	m	n	n1	w	s				
PRODN-550DC	G1	G1	G1	45	46	259	55	55	205	171	248	99	170	138	106	13.5	15.7	16.4	297x255x295	
PRODN-900DC	G1½	G1½	G1½	47	51	260	57	57	236	181	252	99	170	138	106	13.5	16.3	17	297x255x295	

CHW-Z/ZER

Self-priming Multi-stage Centrifugal Pump



CHW-Z



CHW-ZER



CHM-ZER

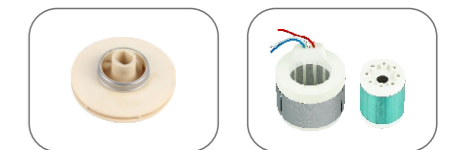

Features

- Energy conservation
- Wide voltage
- Self-priming
- Permanent magnet motor
- Frost protection
- Constant pressure
- Compact and lightweight
- Low noise
- Food grade overflow parts (option)
- Multi-protection

Model Instruction

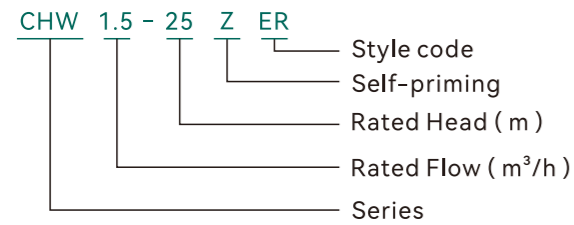

Whole-house water pressure boosting for residential use



Working Conditions

pH Value	5-8
Ambient temperature	0-40°C
Ambient humidity	Max.85% (RH)
Medium temperature	0-60°C(The maximum temperature of liquid not over than 75°C)

Performance Data

Model	CHW1.5-25Z	CHW2-32Z	CHW3-40Z
Power(W)	370	550	750
Max.Q(m ³ /h)	5.0	5.5	7.0
Rated.Q(m ³ /h)	1.5	2.0	3.0
Max.H(m)	30	45	48
Rated.H(m)	25	32	40
Speed(r/min)	4500	4000	4000
Current(A)	2.5	3.5	5.8
Voltage(V)	220/110	220/110	220/110
Frequency(Hz)	50/60	50/60	50/60
Self-priming Head(m)	5	7.5	7.5
Inlet(mm)	25	25	25
Outlet(mm)	25	25	25

Model	CHW1.5-25ZER	CHW2-32ZER	CHW3-40ZER	CHW1.5-42ZER
Power(W)	370	550	750	750
Max.Q(m ³ /h)	5.0	5.5	7.0	5.0
Rated.Q(m ³ /h)	1.5	2.0	3.0	1.5
Max.H(m)	30	45	48	60
Rated.H(m)	25	32	40	42
Speed(r/min)	4500	4000	4000	4900
Current(A)	2.5	3.5	5.8	6.0
Voltage(V)	220/110	220/110	220/110	220/110
Frequency(Hz)	50/60	50/60	50/60	50/60
Self-priming Head(m)	5	7.5	7.5	7.5
Inlet(mm)	25	25	25	25
Outlet(mm)	25	25	25	25

Model	CHM2-2ZR	CHM2-4ZR	CHM3-4ZR
Power(W)	370	550	750
Max.Q(m ³ /h)	5.0	5.5	7.0
Rated.Q(m ³ /h)	1.5	2.0	3.0
Max.H(m)	30	45	48
Rated.H(m)	25	32	40
Speed(r/min)	4500	4000	4000
Current(A)	2.5	3.5	6.0
Voltage(V)	220	220	220
Frequency(Hz)	50/60	50/60	50/60
Self-priming Head(m)	5	7.5	7.5
Inlet(mm)	25	25	25
Outlet(mm)	25	25	25

Model	CHM2-2ZER	CHM2-4ZER	CHM3-4ZER
Power(W)	370	550	750
Max.Q(m ³ /h)	5.0	5.5	7.0
Rated.Q(m ³ /h)	1.5	2.0	3.0
Max.H(m)	30	45	48
Rated.H(m)	25	32	40
Speed(r/min)	4500	4000	4000
Current(A)	2.5	3.5	6.0
Voltage(V)	220	220	220
Frequency(Hz)	50/60	50/60	50/60
Self-priming Head(m)	5	7.5	7.5
Inlet(mm)	25	25	25
Outlet(mm)	25	25	25

Performance Curve

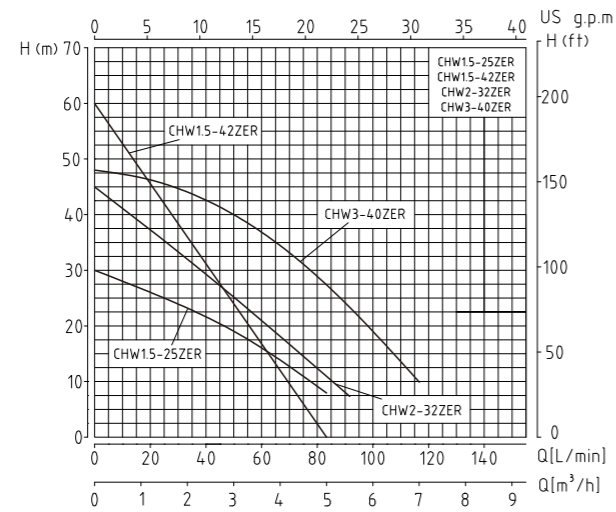

Installation Dimensions

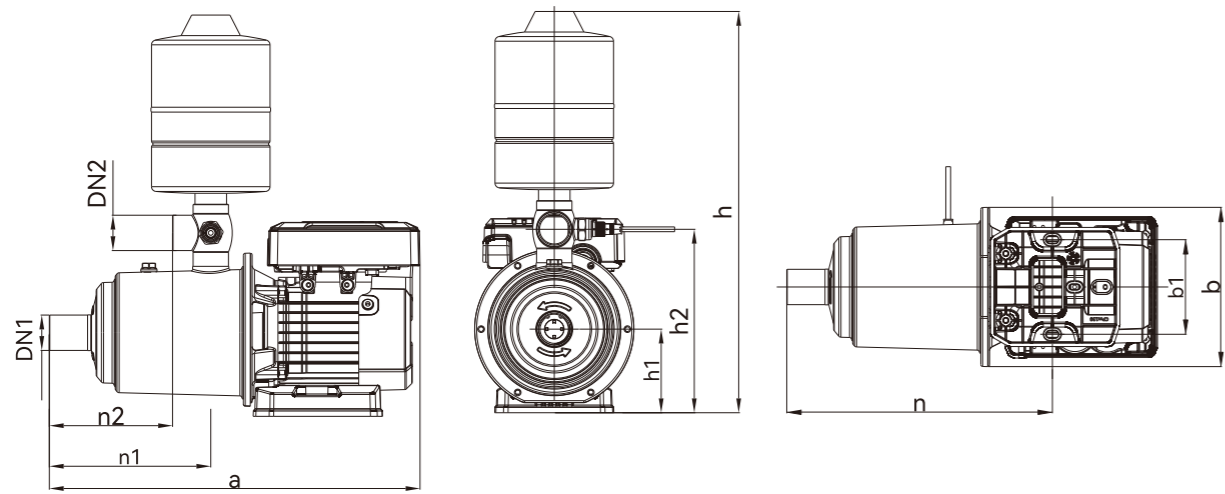

Model	DN1	DN2	Dimensions (mm)									N.W. (kg)	G.W. (kg)	Carton size (mm)
			a	b	b1	h	h1	h2	n	n1	n2			
CHW1.5-25Z	G1	G1	335	167	99	420	88	192	225	116	76	7.3	7.8	575x215X275
CHW2-32Z	G1	G1	388	167	99	420	88	192	278	169	129	7.8	8.3	575x215X275
CHW3-40Z	G1	G1	388	167	99	420	88	192	278	169	129	8.1	8.6	575x215X275

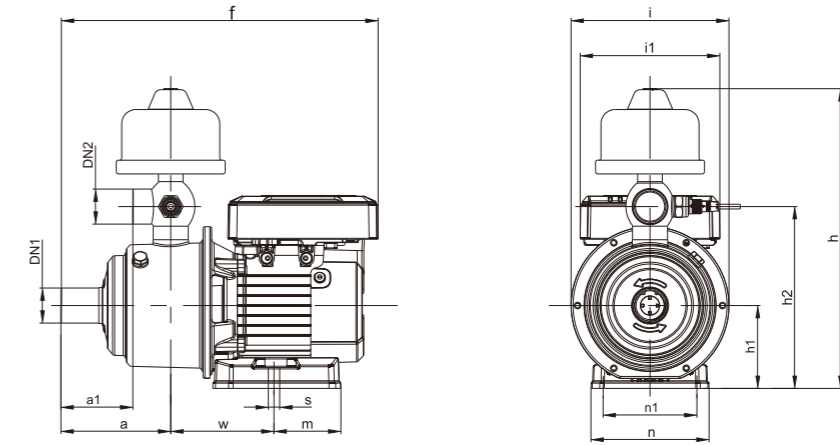

Model	DN1	DN2	Dimensions (mm)													N.W. (kg)	G.W. (kg)	Carton size (mm)
			a	a1	f	h1	h2	h	l	i1	w	m	s	n	n1			
CHW1.5-25ZER	G1	G1	116	76	335	87.5	192	316.5	167	147.5	109	71	13	125	99	6.8	7.3	380x230x385
CHW2-32ZER	G1	G1	169	129	388	87.5	192	316.5	167	147.5	109	71	13	125	99	7.3	7.8	433x230x385
CHW3-40ZER	G1	G1	169	129	388	87.5	192	316.5	167	147.5	109	71	13	125	99	7.7	8.2	433x230x385
CHW1.5-42ZER	G1	G1	169	129	388	87.5	192	316.5	167	147.5	109	71	13	125	99	7.9	8.4	433x230x385

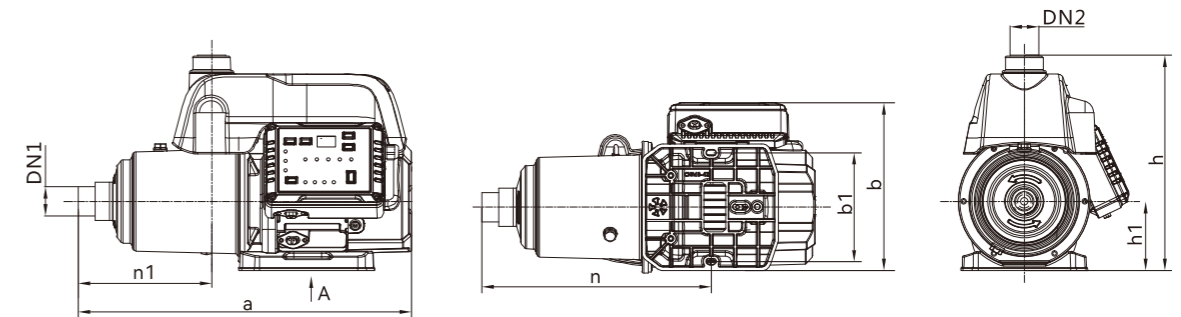

Model	DN1	DN2	Dimensions (mm)							N.W. (kg)	G.W. (kg)	Carton size (mm)
			a	b	b1	h	h1	n	n1			
CHM2-2ZR	G1	G1	368	215	138	273	88	237	116	7.2	8.4	419x260X325
CHM2-4ZR	G1	G1	421	215	138	273	88	290	169	8.2	8.9	472X260X325
CHM3-4ZR	G1	G1	421	215	138	273	88	290	169	8.7	9.4	472X260X325

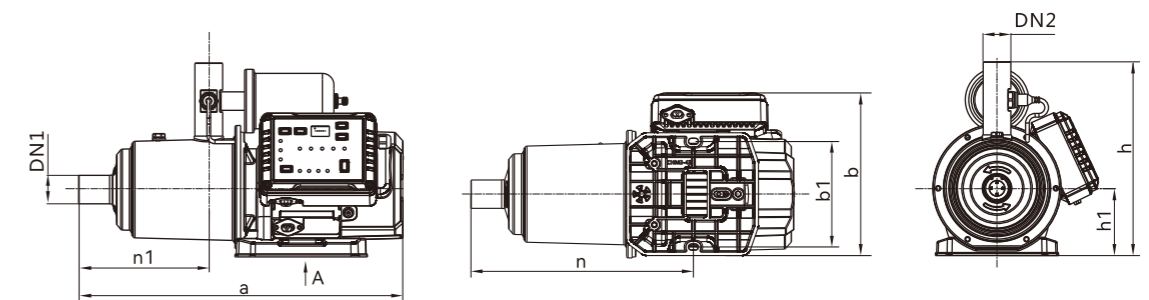

Model	DN1	DN2	Dimensions (mm)							N.W. (kg)	G.W. (kg)	Carton size (mm)
			a	b	b1	h	h1	n	n1			
CHM2-2ZE	G1	G1	368	215	138	252	88	237	116	7.4	8.1	419x260X290
CHM2-4ZE	G1	G1	421	215	138	252	88	290	169	7.9	8.6	472X260X290
CHM3-4ZE	G1	G1	421	215	138	252	88	290	169	8.4	9.1	472X260X290

CHW-R

Multi-stage Centrifugal Pump



Features

- ⊙ Energy conservation
- ⊙ Permanent magnet motor
- ⊙ Constant pressure
- ⊙ Low noise
- ⊙ Multi-protection
- ⊙ Wide voltage
- ⊙ Frost protection
- ⊙ Compact and lightweight
- ⊙ Food grade overflow parts
- ⊙ Parallel function (option)

Model Instruction

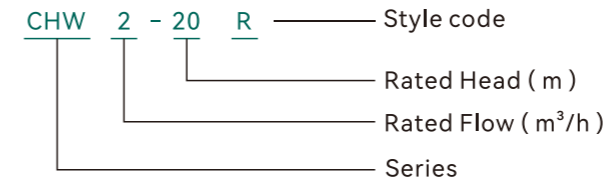

Whole-house water pressure boosting for residential use



Working Conditions

pH Value	5-8
Ambient temperature	0-40°C
Ambient humidity	Max.85% (RH)
Medium temperature	0-60°C(The maximum temperature of liquid not over than 75°C)

Performance Data

Model	CHW2-20R1	CHW2-32R1	CHW3-50R1
Power(W)	370	550	1100
Max.Q(m³/h)	4.1	4.2	5.5
Rated.Q(m³/h)	2.0	2.0	3.0
Max.H(m)	32	42	65
Rated.H(m)	20	32	50
Speed(r/min)	6000	4800	6200
Current(A)	1.7	2.9	5.3
Voltage(V)	220/110	220/110	220
Frequency(Hz)	50/60	50/60	50/60
Self-priming Head(m)	/	/	/
Inlet(mm)	25	25	25
Outlet(mm)	25	25	25
Multi-Pump	×	×	×

Model	CHW8-30R1	CHW8-45R1	CHW12-30R1
Power(W)	1500	2200	2200
Max.Q(m³/h)	12	14	14
Rated.Q(m³/h)	8.0	8.0	12
Max.H(m)	42	62	62
Rated.H(m)	30	45	30
Speed(r/min)	4000	4800	4800
Current(A)	6.0	9.6	9.6
Voltage(V)	220	220	220
Frequency(Hz)	50/60	50/60	50/60
Self-priming Head(m)	/	/	/
Inlet(mm)	40	50	50
Outlet(mm)	40	50	50
Multi-Pump	●	●	●

Installation Dimensions

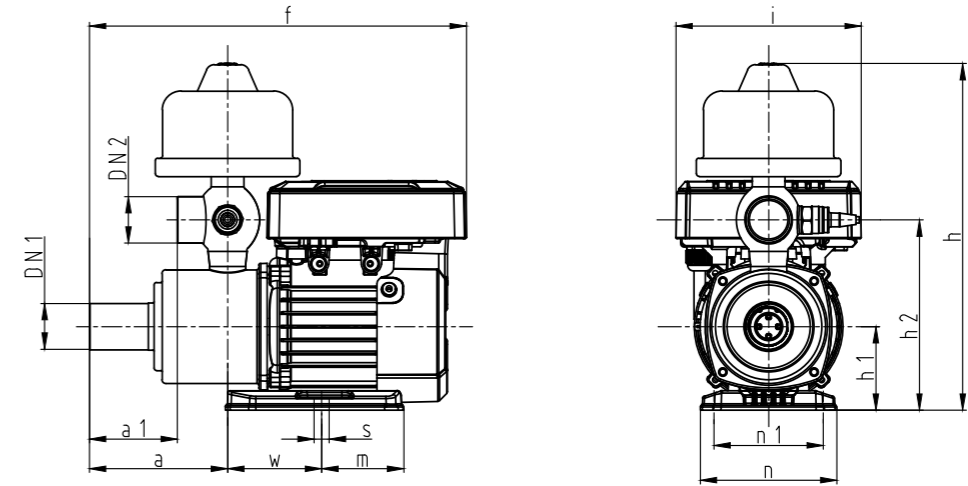

Performance Curve

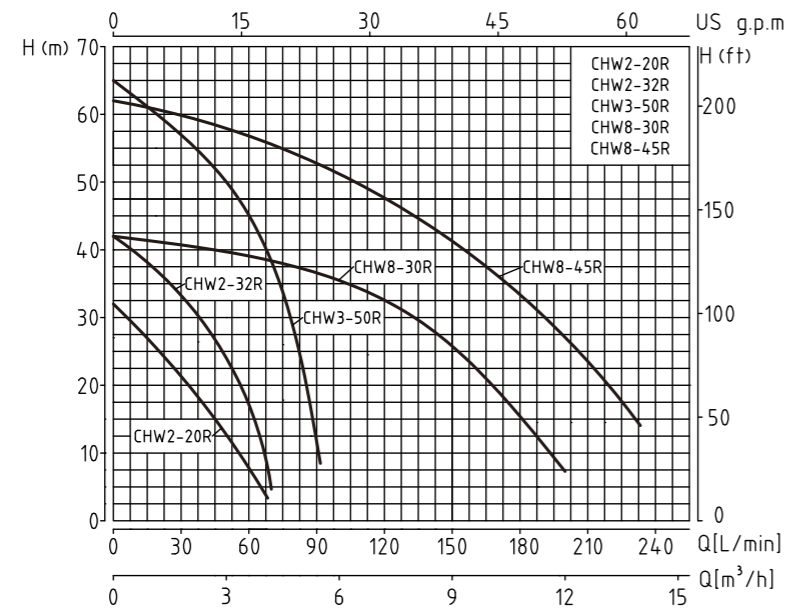

Model	DN1	DN2	Dimensions (mm)											N.W. (kg)	G.W. (kg)	Carton size (mm)	
			a	a1	f	h1	h2	h	i	w	m	s	n				n1
CHW2-20R	G1	G1	77	37	267	66.5	151.5	276	147.5	75	65	12	109	87	4.7	5.1	318x205x340
CHW2-32R	G1	G1	110	70	300	66.5	151.5	276	147.5	75	65	12	109	87	5.0	5.4	345x205x340
CHW3-50R	G1	G1	110	70	300	66.5	151.5	276	147.5	75	65	12	109	87	5.4	5.8	345x205x340
CHW8-30R	G1½	G1½	157	88	396	76	187	453	165	108.5	86	12	117	139	10	11.1	594x214x308
CHW8-45R	G2	G2	157	88	396	76	187	453	165	108.5	86	12	117	139	11	12	594x214x308
CHW12-30R	G2	G2	157	88	396	76	187	453	165	108.5	86	12	117	139	11	12	594x214x308

CHW2-20R/CHW-32R/CHW3-50R : 1L pressure tank CHW8-30R/CHW8-45R/CHW12-30R: 3L pressure tank

CHW-DC

Multi-stage Centrifugal Pump



Features

- ⊙ Energy conservation
- ⊙ Permanent magnet motor
- ⊙ Constant pressure
- ⊙ Low noise
- ⊙ Multi-protection
- ⊙ Wide voltage
- ⊙ Frost protection
- ⊙ Compact and lightweight
- ⊙ Food grade overflow parts
- ⊙ Parallel function (option)

Model Instruction

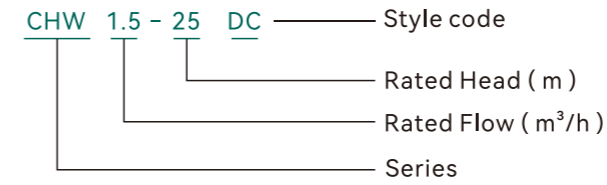

Whole-house water pressure boosting for residential use



Working Conditions

pH Value	5-8
Ambient temperature	0-40°C
Ambient humidity	Max.85% (RH)
Medium temperature	0-60°C(The maximum temperature of liquid not over than 75°C)

Performance Data

Model	CHW1.5-25DCR1	CHW4-30DCR1	CHW4-45DCR1	CHW8-30DCR1
Power(W)	370	750	1500	1500
Max.Q(m³/h)	4.4	8.0	7.5	12
Rated.Q(m³/h)	1.5	4.0	4.0	8.0
Max.H(m)	38	37	55	42
Rated.H(m)	25	30	45	30
Speed(r/min)	4200	4000	4000	4000
Current(A)	2.7	6.0	5.8	6.0
Voltage(V)	220/110	220/110	220	220
Frequency(Hz)	50/60	50/60	50/60	50/60
Self-priming Head(m)	/	/	/	/
Inlet(mm)	25	25	25	40
Outlet(mm)	25	25	25	40
Multi-Pump	×	×	●	●

Model	CHW8-45DCR1	CHW12-30DCR1	CHW2-82DCR1	CHW2-115DCR1
Power(W)	2200	2200	1500	2200
Max.Q(m³/h)	14	14	5.5	5.5
Rated.Q(m³/h)	8.0	12	2.0	2.0
Max.H(m)	62	62	90	122
Rated.H(m)	45	30	82	115
Speed(r/min)	4800	4800	5300	5300
Current(A)	9.6	9.6		
Voltage(V)	220	220	220	220
Frequency(Hz)	50/60	50/60	50/60	50/60
Self-priming Head(m)	/	/	/	/
Inlet(mm)	50	50	25	25
Outlet(mm)	50	50	25	25
Multi-Pump	●	●	●	●

Performance Curve

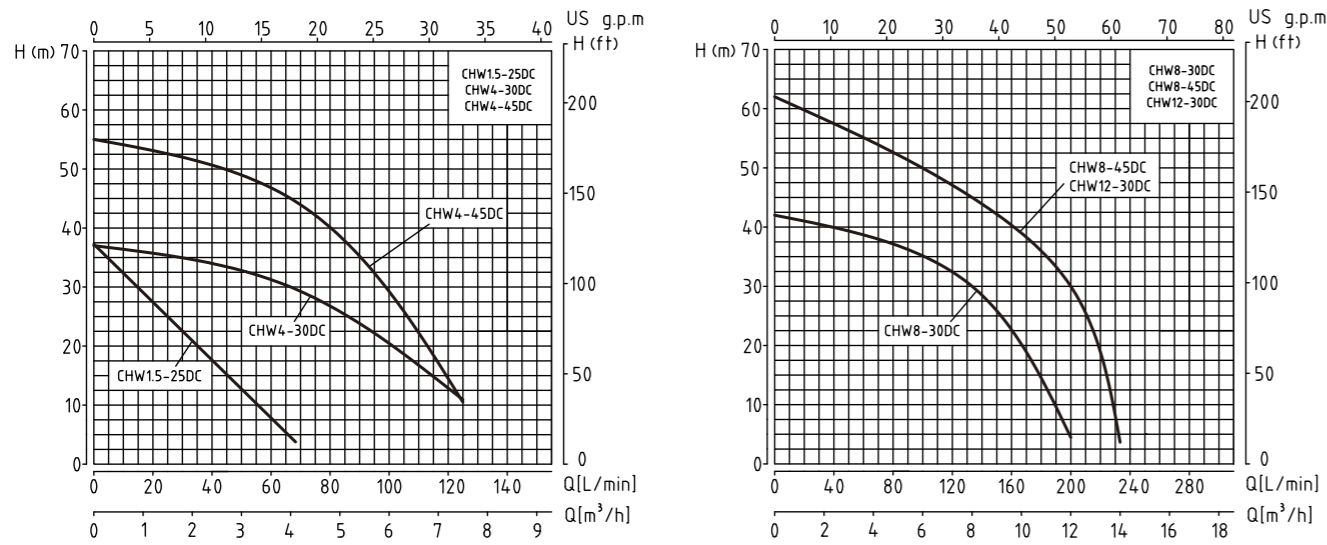

Installation Dimensions

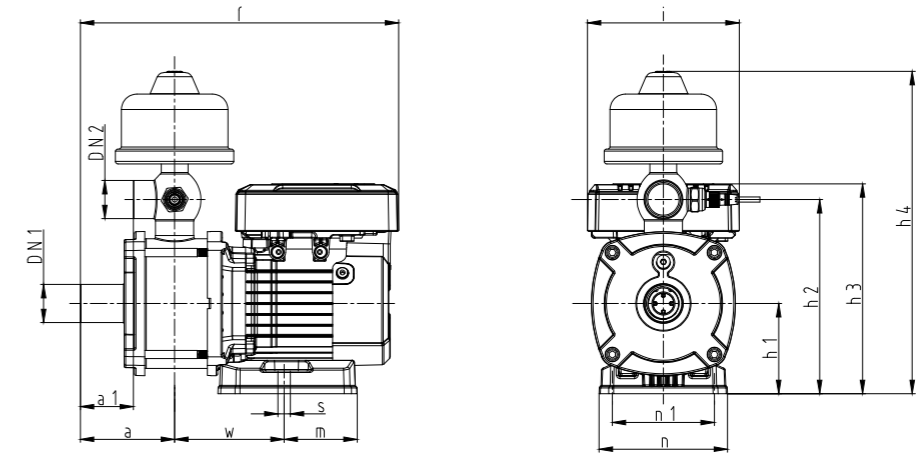

Model	DN1	DN2	Dimensions (mm)													N.W. (kg)	G.W. (kg)	Carton size (mm)
			a	a1	f	h1	h2	H3	h	l	w	m	s	n	n1			
CHW1.5-25DC	G1	G1	91.5	51.5	309	87.5	188.5	204	313	147.5	106.5	71	13	125	99	6.3	6.8	360x220x365
CHW4-30DC	G1	G1	91.5	51.5	309	87.5	188.5	204	313	147.5	106.5	71	13	125	99	6.8	7.1	360x220x365
CHW4-45DC	G1	G1	118.5	78.5	365	87.5	188.5	234	313	147.5	106.5	71	13	125	99	8.1	9.0	420x245x370

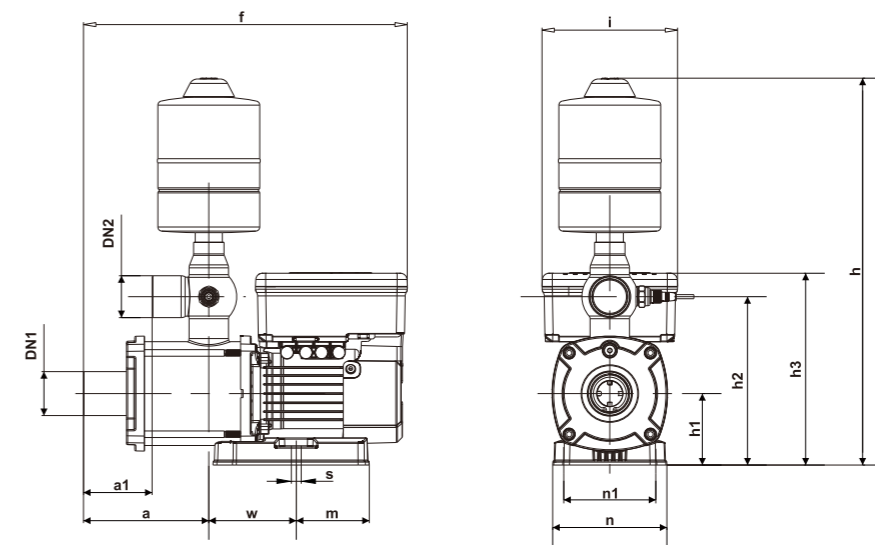

Model	DN1	DN2	Dimensions (mm)													N.W. (kg)	G.W. (kg)	Carton size (mm)
			a	a1	f	h1	h2	H3	h	l	w	m	s	n	n1			
CHW8-30DC	G1 ½	G1 ½	152.5	83.5	394	87	205	233.5	471	165	106.5	89	11	139	112	9.5	10.4	610x210x340
CHW8-45DC	G2	G2	154.5	85.5	396	87	205	233.5	471	165	106.5	89	11	139	112	10.5	11.4	610x210x340
CHW12-30DC	G2	G2	154.5	85.5	396	87	205	233.5	471	165	106.5	89	11	139	112	10.5	11.4	610x210x340
CHW2-82DC	G1	G1	91.5	51.5	339.5	87	188	233.5	418.5	165	111	89	11	139	112			
CHW2-115DC	G1	G1	109.5	69.5	357.5	87	188	233.5	418.5	165	111	89	11	139	112			

CHM-DC/CDW

Multi-stage Centrifugal Pump

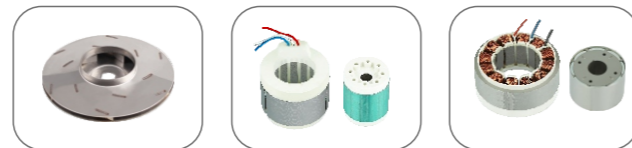

Features

- Energy conservation
- Permanent magnet motor
- Constant pressure
- Low noise
- Multi-protection
- Wide voltage
- Frost protection
- Compact and lightweight
- Food grade overflow parts
- Timing mode (option)
- APP function(option)
- Parallel function(option)

Model Instruction

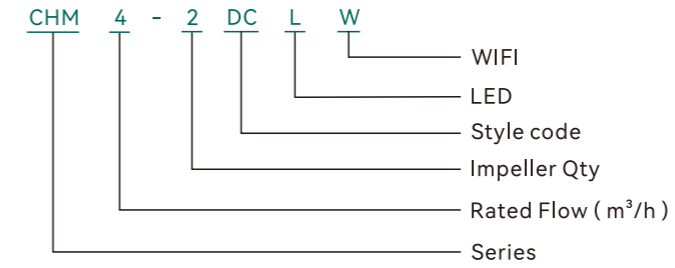

Whole-house water pressure boosting for residential use



Working Conditions

pH Value	5-8
Ambient temperature	0-40°C
Ambient humidity	Max.85% (RH)
Medium temperature	0-60°C(The maximum temperature of liquid not over than 75°C)

Performance Data

Model	CHM2-2DC	CHM4-2DCR	CHM4-3DCR
Power(W)	370	750	1500
Max.Q(m ³ /h)	4.4	8.0	8.0
Rated.Q(m ³ /h)	1.5	4.0	4.0
Max.H(m)	38	37	55
Rated.H(m)	25	30	45
Speed(r/min)	4500	4000	4000
Current(A)	2.5	6.0	5.8
Voltage(V)	220/127	220/127	220/127
Frequency(Hz)	50/60	50/60	50/60
Self-priming Head(m)	/	/	/
Inlet(mm)	25	32	32
Outlet(mm)	25	25	25
Multi-Pump	×	×	×
WiFi	×	×	×

Model	CHM4-2DCLW	CHM4-3DCLW	CHM4-2DCY	CHM4-3DCY
Power(W)	750	1500	750	1500
Max.Q(m³/h)	8.0	8.0	8.0	8.0
Rated.Q(m³/h)	4.0	4.0	4.0	4.0
Max.H(m)	37	55	37	55
Rated.H(m)	30	45	30	45
Speed(r/min)	4000	4000	4000	4000
Current(A)	6.0	5.8	6.0	5.8
Voltage(V)	220/127	220/127	220/127	220/127
Frequency(Hz)	50/60	50/60	50/60	50/60
Self-priming Head(m)	/	/	/	/
Inlet(mm)	32	32	25	25
Outlet(mm)	25	25	25	25
Multi-Pump	×	×	×	×
WiFi	●	●	●	●

Model	CDW4-40W	CDW4-45W
Power(W)	750	1500
Max.Q(m³/h)	8.0	8.0
Rated.Q(m³/h)	4.0	4.0
Max.H(m)	37	55
Rated.H(m)	30	45
Speed(r/min)	4000	4000
Current(A)	6.2	6.2
Voltage(V)	220	220
Frequency(Hz)	50/60	50/60
Self-priming Head(m)	/	/
Inlet(mm)	32	32
Outlet(mm)	25	25
Multi-Pump	●	●
WiFi	●	●

Performance Curve

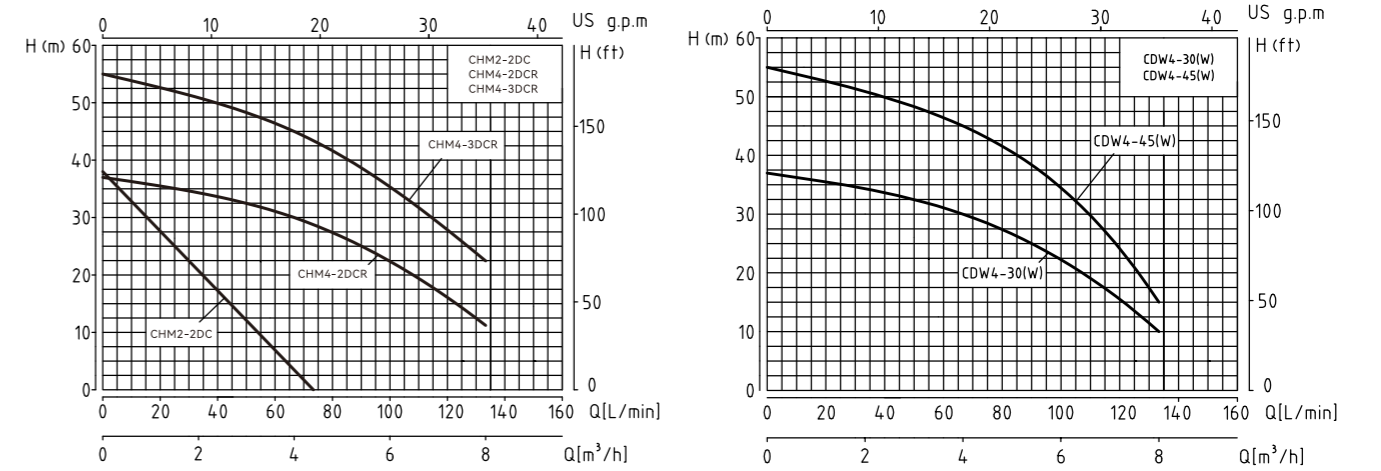

Installation Dimensions

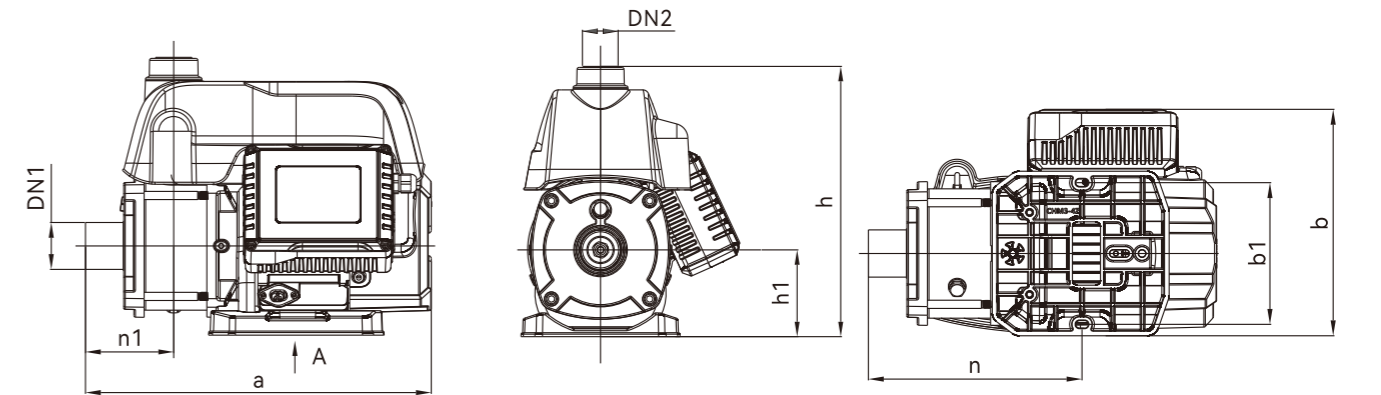

Model	DN1	DN2	Dimensions (mm)							N.W. (kg)	G.W. (kg)	Carton size (mm)
			a	b	b1	h	h1	n	n1			
CHM2-2DC	G1	G1	337	203	138	273	88	213	92	7.2	8.0	394x260X330
CHM4-2DCR	G1¼	G1	339	212	138	273	88	208	87	8.8	9.5	394x260X330
CHM4-3DCR	G1¼	G1	366	222	138	273	88	235	114	10	11	420x260X330
CHM4-2DCLW	G1	G1	338	215	138	273	88	207	86	8.8	9.5	394x260X330
CHM4-3DCLW	G1	G1	369	225	138	273	88	234	113	10	11	420x260X330

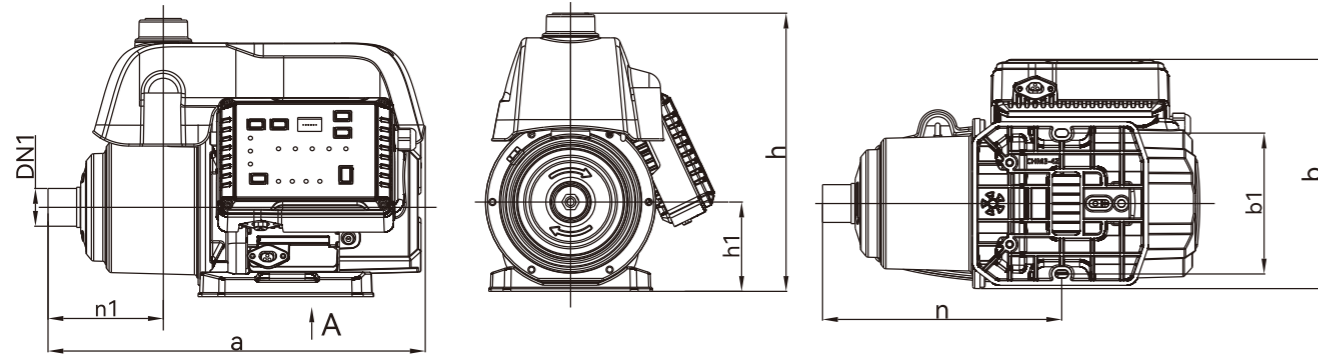

Model	DN1	DN2	Dimensions (mm)								N.W. (kg)	G.W. (kg)	Carton size (mm)
			a	b	b1	h	h1	n	n1				
CHM4-2DCY	G1	G1	338	215	138	273	88	207	86	8.8	9.5	394x260X330	
CHM4-3DCY	G1	G1	369	225	138	273	88	234	113	10	11	420x260X330	

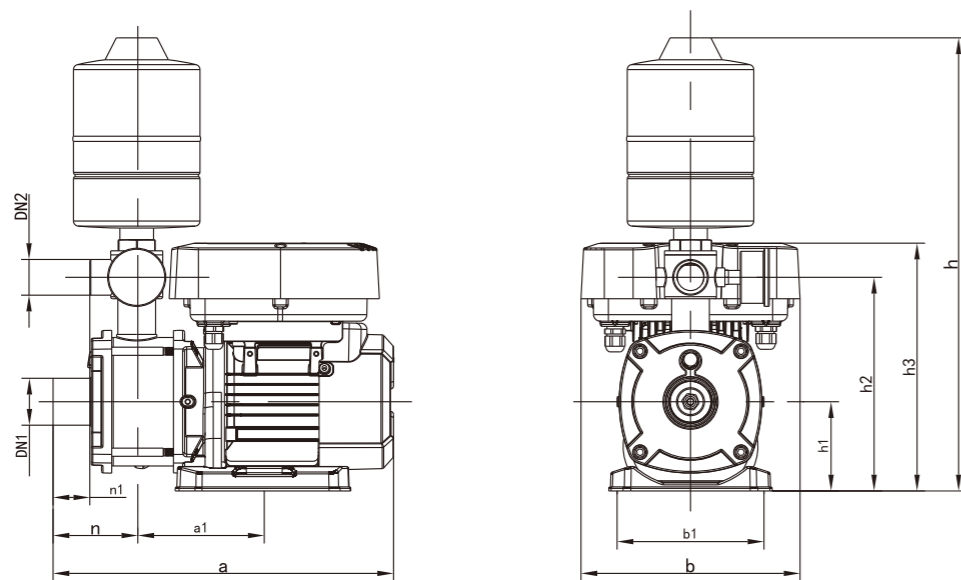

Model	DN1	DN2	Dimensions (mm)										N.W. (kg)	G.W. (kg)	Carton size (mm)
			a	b	a1	b1	h	h1	h2	h3	n	n1			
CDW4-30W	G1¼	G1	334	215	125	138	445	88	210	243	82	36	9	10	555x273x297
CDW4-45W	G1¼	G1	361	215	125	138	445	88	210	243	109	63	9.8	10.8	555x273x297

CHM(T)-DC/DCER

Multi-stage Centrifugal Pump



CHM(T)-DC



CHM-DCER



Features

- ⊙ Energy conservation
- ⊙ Permanent magnet motor
- ⊙ Constant pressure
- ⊙ Low noise
- ⊙ Multi-protection
- ⊙ Wide voltage
- ⊙ Frost protection(option)
- ⊙ Compact and lightweight
- ⊙ Food grade overflow parts
- ⊙ Timing mode (option)
- ⊙ APP function(option)
- ⊙ Parallel function

Model Instruction

CHM T 8 - 3 DC — Style code
 Impeller Qty
 Rated Flow (m³/h)
 Three Phase
 Series

CHM 8 - 3 DCER — Style code
 Impeller Qty
 Rated Flow (m³/h)
 Series

Whole-house water pressure boosting for residential use



Working Conditions

pH Value	5-8
Ambient temperature	0-40°C
Ambient humidity	Max.85% (RH)
Medium temperature	0-60°C(The maximum temperature of liquid not over than 75°C)

Performance Data

Model	CHM4-4DC	CHM6-4DC	CHM8-3DC	CHM12-DC
Power(W)	2200	2200	2200	2200
Max.Q(m ³ /h)	10.5	10.5	13	16
Rated.Q(m ³ /h)	4.0	6.0	8.0	12
Max.H(m)	82	82	55	55
Rated.H(m)	73	65	45	30
Speed(r/min)	4200	4200	4000	4000
Current(A)	9.9	9.9	9.6	9.6
Voltage(V)	220	220	220	220
Frequency(Hz)	50/60	50/60	50/60	50/60
Self-priming Head(m)	/	/	/	/
Inlet(mm)	25	32	40	50
Outlet(mm)	25	25	40	50
Multi-Pump	●	●	●	●
WiFi	●	●	●	●

Model	CHMT4-4DC	CHMT6-4DC	CHMT8-3DC	CHMT12-DC
Power(W)	2200	2200	2200	2200
Max.Q(m ³ /h)	10.5	10.5	13	16
Rated.Q(m ³ /h)	4.0	6.0	8.0	12
Max.H(m)	82	82	55	55
Rated.H(m)	73	65	45	30
Speed(r/min)	4200	4200	4000	4000
Current(A)	5.2	5.2	5.2	5.2
Voltage(V)	380	380	380	380
Frequency(Hz)	50/60	50/60	50/60	50/60
Self-priming Head(m)	/	/	/	/
Inlet(mm)	25	32	40	50
Outlet(mm)	25	25	40	50
Multi-Pump	●	●	●	●
WiFi	●	●	●	●

Model	CHMT16-3DC	CHMT20-3DC	CHM8-3DCER	CHM12-DCER
Power(W)	4000	4000	2200	2200
Max.Q(m ³ /h)	31	31	13	16
Rated.Q(m ³ /h)	16	20	8.0	12
Max.H(m)	60	60	55	55
Rated.H(m)	49	43	45	30
Speed(r/min)	3600	3600	4000	4000
Current(A)	8.8	8.8	9.6	9.6
Voltage(V)	380	380	220	220
Frequency(Hz)	50/60	50/60	50/60	50/60
Self-priming Head(m)	/	/	/	/
Inlet(mm)	50	50	40	50
Outlet(mm)	50	50	40	50
Multi-Pump	●	●	×	×
WiFi	●	●	●	●

Performance Curve

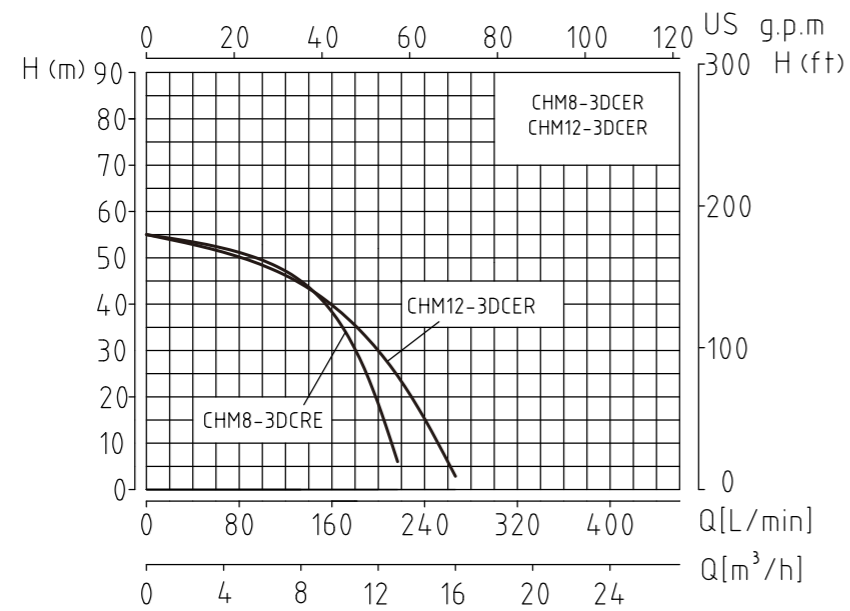
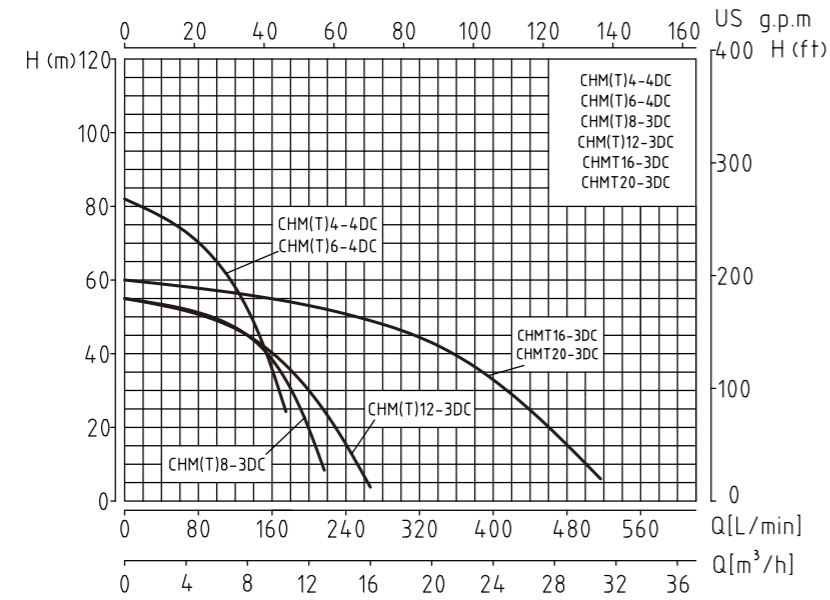

Installation Dimensions

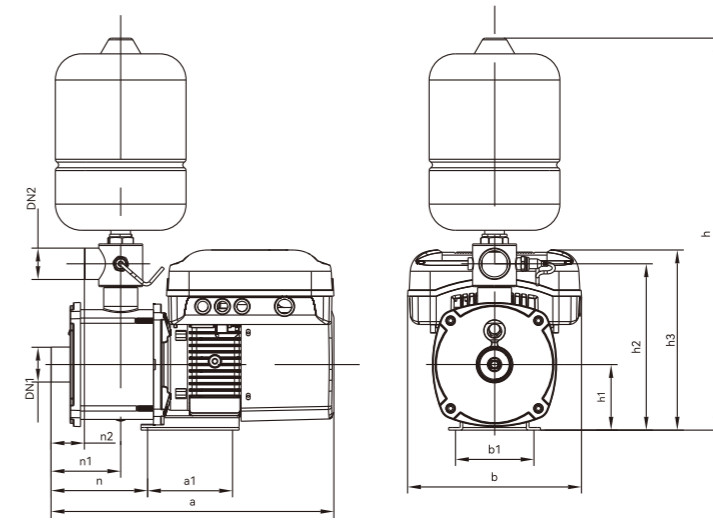

Model	DN1	DN2	Dimensions (mm)											N.W. (kg)	G.W. (kg)	Carton size (mm)
			a	b	a1	b1	h	h1	h2	h3	n	n1	n2			
CHM(T)4-4DC	G1	G1	445	266	120	130	554	102	213	277	155	129	83	19.4	20.5	720x355x375
CHM(T)6-4DC	G1½	G1	445	266	120	130	554	102	223	277	155	129	83	19.4	20.5	720x355x375
CHM(T)8-3DC	G1½	G1½	433	266	120	130	601	102	256	277	143	107	51	20.8	21.6	720x355x375
CHM(T)12-3DC	G2	G2	433	266	120	130	619	102	256	277	143	99	34	21.4	22.2	720x355x375
CHMT16-3DC	G2	G2	500	266	150	130	619	102	256	277	170	137	72	27	28.5	736x341x336
CHMT20-3DC	G2	G2	500	266	150	130	619	102	256	277	170	137	72	27	28.5	736x341x336

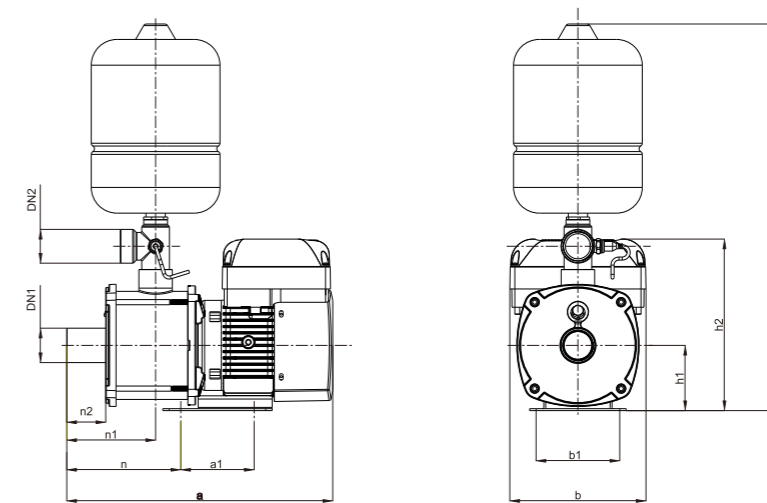

Model	DN1	DN2	Dimensions (mm)											N.W. (kg)	G.W. (kg)	Carton size (mm)
			a	b	a1	b1	h	h1	h2	n	n1	n2				
CHM8-3DCER	G1½	G1½	413	212	120	130	600	102	267	177	138	60	20.1	20.9	720x355x375	
CHM12-3DCER	G2	G2	413	212	120	130	607	102	267	177	131	60	20.3	21.1	720x355x375	

CPm

Single-stage Centrifugal Pump



CPm130P



CPm130



CPm130PR1



CPm158SR1

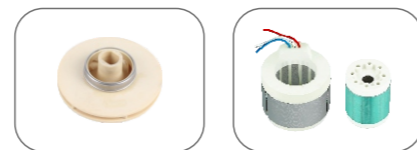

Features

- ⊙ Energy conservation
- ⊙ Permanent magnet motor
- ⊙ Constant pressure
- ⊙ Low noise
- ⊙ Multi-protection
- ⊙ Wide voltage
- ⊙ Frost protection
- ⊙ Compact and lightweight

Model Instruction



Whole-house water pressure boosting for residential use



Working Conditions

pH Value	5-8
Ambient temperature	0-40°C
Ambient humidity	Max.85% (RH)
Medium temperature	0-60°C(The maximum temperature of liquid not over than 75°C)

Performance Data

Model	CPm130P	CPm130	CPm158	CPm158S
Power(W)	370	370	750	750
Max.Q(m³/h)	4.9	4.9	6.8	6.8
Rated.Q(m³/h)	3.0	3.0	3.6	3.6
Max.H(m)	21	21	35	35
Rated.H(m)	15	15	27	27
Speed(r/min)	3000	3000	4000	4000
Current(A)	2.1	2.1	5.8	5.8
Voltage(V)	220/110	220/110	220/110	220/110
Frequency(Hz)	50/60	50/60	50/60	50/60
Self-priming Head(m)	/	/	/	/
Inlet(mm)	25	25	25	25
Outlet(mm)	25	25	25	25

Model	CPm130PR1	CPm158SR1
Power(W)	370	750
Max.Q(m³/h)	4.9	6.8
Rated.Q(m³/h)	3.0	3.6
Max.H(m)	21	35
Rated.H(m)	15	27
Speed(r/min)	3000	4000
Current(A)	2.1	5.8
Voltage(V)	220/110	220/110
Frequency(Hz)	50/60	50/60
Self-priming Head(m)	/	/
Inlet(mm)	25	25
Outlet(mm)	25	25

Performance Curve

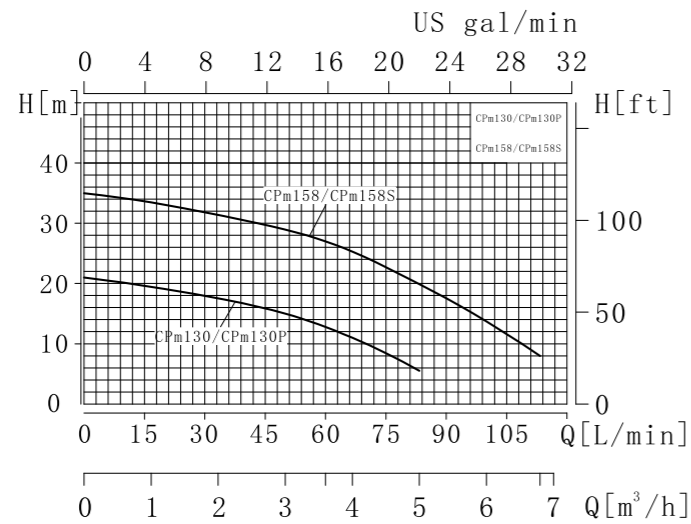

Installation Dimensions

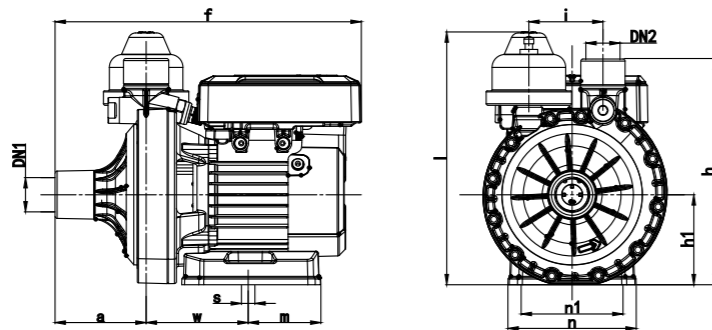

Model	DN1	DN2	Dimensions (mm)											N.W. (kg)	G.W. (kg)	Carton size (mm)
			a	f	h	h1	i	l	m	n	n1	w	s			
CPm130P	G1	G1	89	298	220	88	72	241	71	125	99	99	13	5.8	6.5	345x230x295

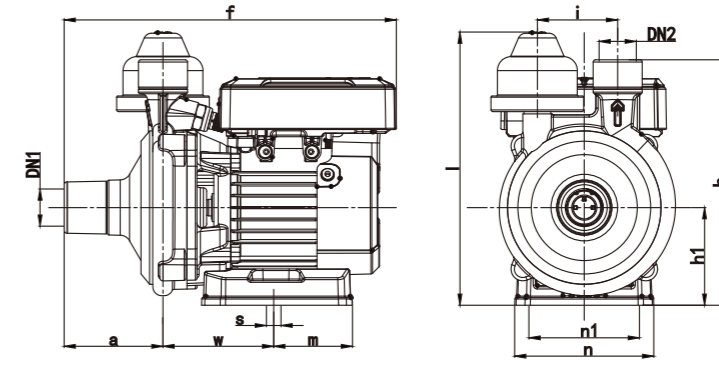

Model	DN1	DN2	Dimensions (mm)											N.W. (kg)	G.W. (kg)	Carton size (mm)
			a	f	h	h1	i	l	m	n	n1	w	s			
CPm130	G1	G1	89	298	220	88	72	242	71	125	99	99	13	7.5	8.2	345x230x295
CPm158	G1	G1	89	298	220	88	72	241	71	125	99	99	13	8.2	8.9	345x230x295
CPm158S	G1	G1	89	298	220	88	72	241	71	125	99	99	13	8.3	9.0	345x230x295

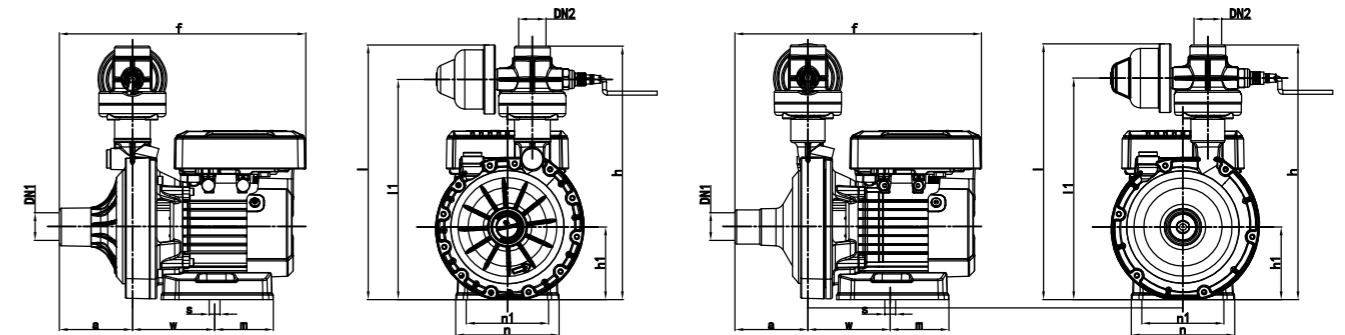

Model	DN1	DN2	Dimensions (mm)											N.W. (kg)	G.W. (kg)	Carton size (mm)
			a	f	h	h1	l	l1	m	n	n1	w	s			
CPm130PR1	G1	G1	88	297	307	88	309	267	71	125	99	99	13	6.1	7.0	345x242x345
CPm158SR1	G1	G1	89	297	307	88	309	267	71	125	99	99	13	8.2	9.1	345x242x345

PB

Single-stage Centrifugal Pump

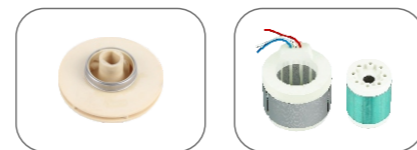

Features

- ⦿ Energy conservation
- ⦿ Permanent magnet motor
- ⦿ Low noise
- ⦿ Multi-protection
- ⦿ Wide voltage
- ⦿ Frost protection
- ⦿ Compact and lightweight

Model Instruction

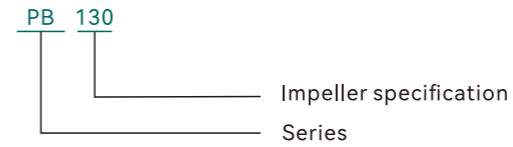

Whole-house water pressure boosting for residential use



Working Conditions

pH Value	5-8
Ambient temperature	0-40°C
Ambient humidity	Max.85% (RH)
Medium temperature	0-60°C(The maximum temperature of liquid not over than 75°C)

Performance Data

Model	PB130	PB158
Power(W)	370	750
Max.Q(m³/h)	4.9	6.8
Rated.Q(m³/h)	3.0	3.6
Max.H(m)	21	35
Rated.H(m)	15	27
Speed(r/min)	3000	4000
Current(A)	2.1	5.8
Voltage(V)	220	220
Frequency(Hz)	50/60	50/60
Self-priming Head(m)	/	/
Inlet(mm)	25	25
Outlet(mm)	25	25

Performance Curve

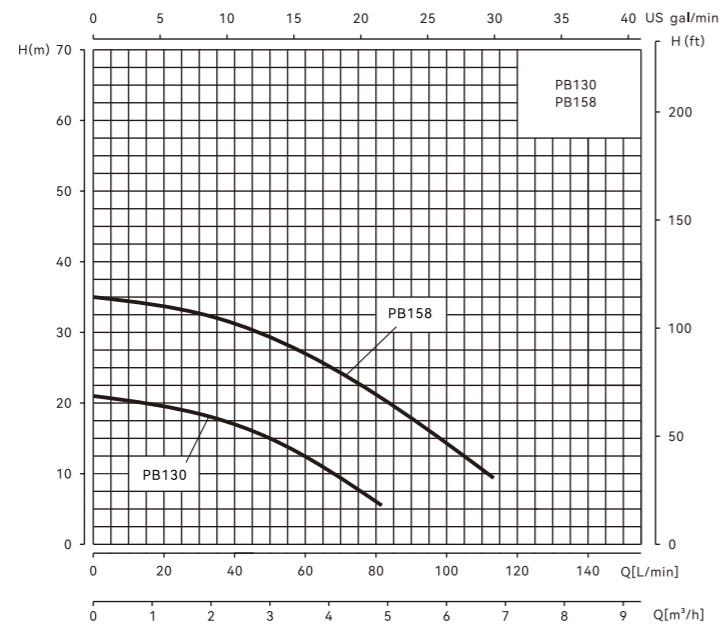

Installation Dimensions

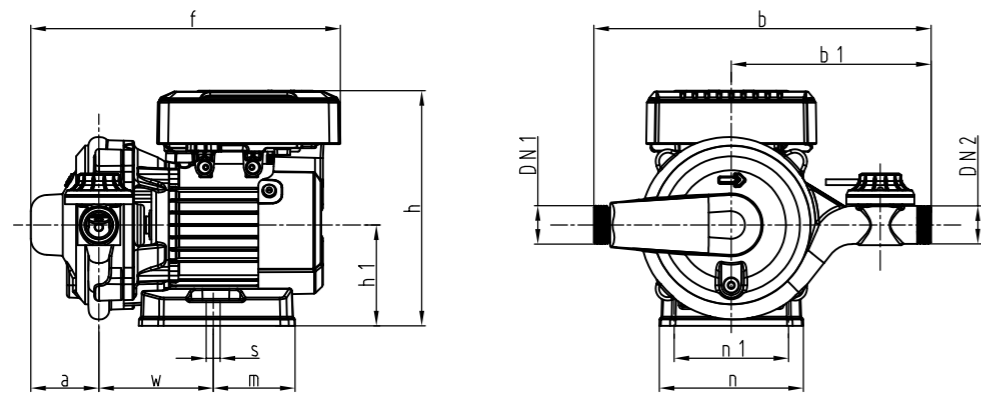

Model	DN1	DN2	Dimensions (mm)											N.W. (kg)	G.W. (kg)	Carton size (mm)
			a	f	h	h1	i	l	m	n	n1	w	s			
PB130	G1	G1	59	268	87.5	204	292	173	99	71	13	125	99	7.3	8.1	333x313x277
PB158	G1	G1	59	268	87.5	204	292	173	99	71	13	125	99	7.7	8.5	333x313x277

SCM

Single-stage Centrifugal Pump



Features

- Energy conservation
- Permanent magnet motor
- Constant pressure
- Low noise
- Multi-protection
- Wide voltage
- Frost protection
- Compact and lightweight
- Food grade overflow parts
- APP function
- Parallel function

Model Instruction

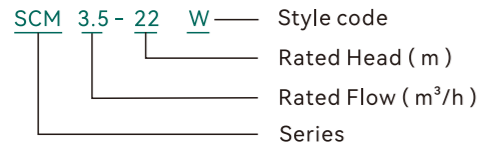

Whole-house water pressure boosting for residential use



Working Conditions

pH Value	5-8
Ambient temperature	0-40°C
Ambient humidity	Max.85% (RH)
Medium temperature	0-60°C(The maximum temperature of liquid not over than 75°C)

Performance Data

Model	SCM3.5-22W	SCM10-16W
Power(W)	750	1100
Max.Q(m³/h)	7.5	16
Rated.Q(m³/h)	3.5	10
Max.H(m)	26	22
Rated.H(m)	22	16
Speed(r/min)	4000	4000
Current(A)	5.4	5.1
Voltage(V)	220	220
Frequency(Hz)	50/60	50/60
Self-priming Head(m)	/	/
Inlet(mm)	32	40
Outlet(mm)	32	40
Multi-Pump	●	●
WiFi	●	●

Performance Curve

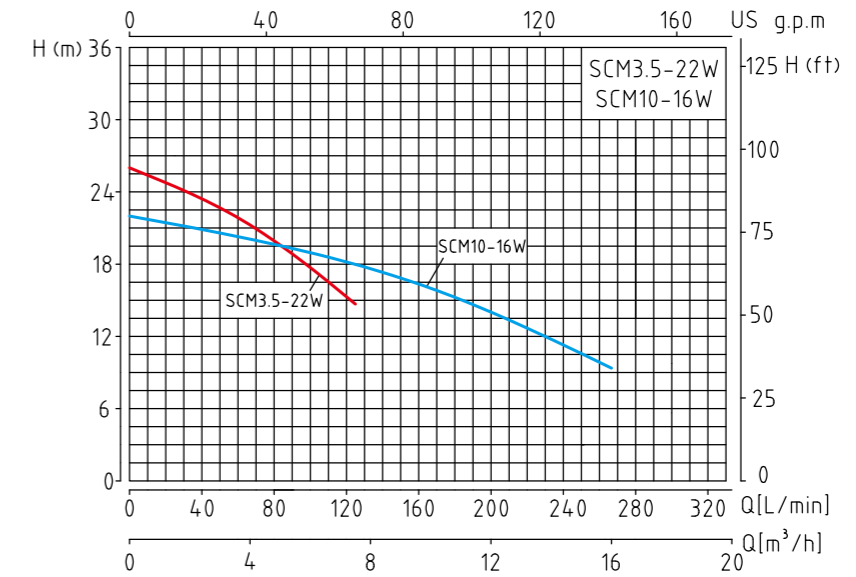

Installation Dimensions

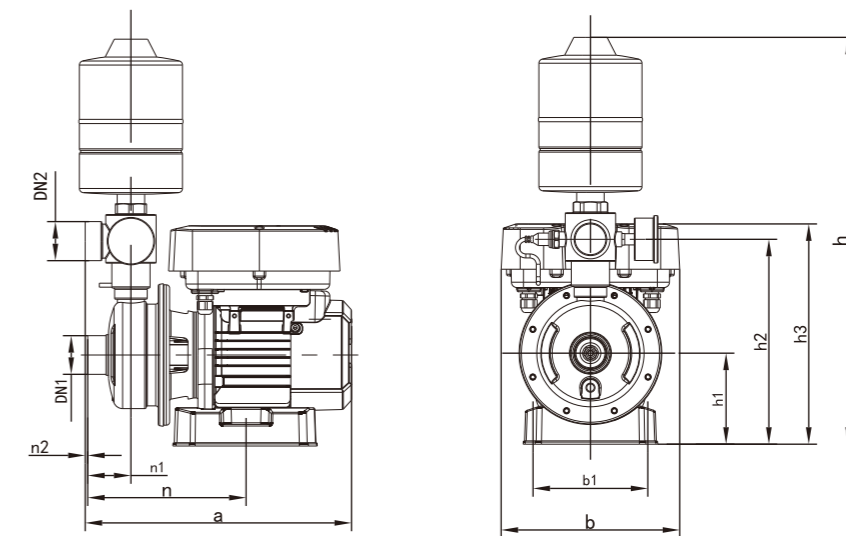

Model	DN1	DN2	Dimensions (mm)										N.W. (kg)	G.W. (kg)	Carton size (mm)
			a	b	b1	h	h1	h2	h3	n	n1	n2			
SCM3.5-22W	G1 ¼	G1 ¼	320	215	138	490	110	247	265	188	49	3	8.8	9.8	500x270x312
SCM10-16W	G1 ½	G1 ½	321	215	138	504	110	265	265	188	42	14	9.1	10.1	500x270x312

SSP

Permanent Magnet Variable Frequency Swimming Pool Pump

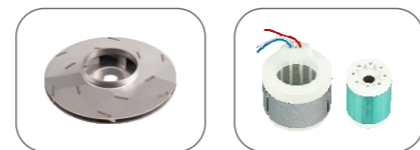
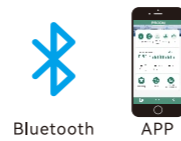

Features

- ⦿ Multiple Patented Technologies
- ⦿ Dual Water-Land Application
- ⦿ APP Smart Control
- ⦿ Adjustable Speed Levels
- ⦿ Automatic Stop in Case of Water Shortage
- ⦿ Wide Voltage Adaptation
- ⦿ Comprehensive Safety Protection

Model Instruction

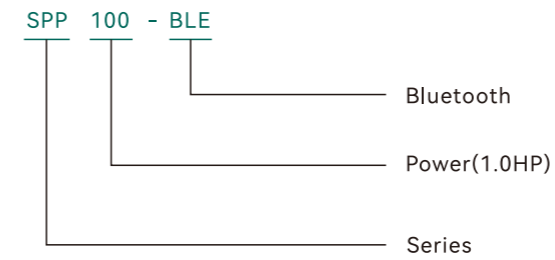

Swimming Pool



Working Conditions

Operating conditions	Above-ground / Submersible
Diving depth	≤ 0.5m
Waterproof grade	IP65

Performance Data

Model	SPP100	SPP100-BLE
Power(W)	900	900
Max.Q(m³/h)	16.5	16.5
Max.H(m)	15.8	15.8
Speed(r/min)	4000	4000
Current(A)		
Voltage(V)	220	220
Frequency(Hz)	50/60	50/60
Inlet(mm)	50	50
Outlet(mm)	50	50
Bluetooth	×	●

Performance Curve

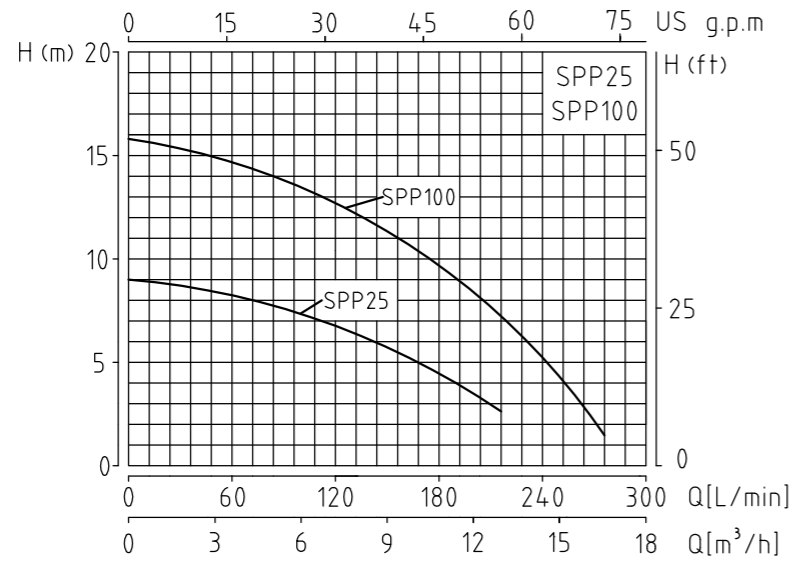

Installation Dimensions

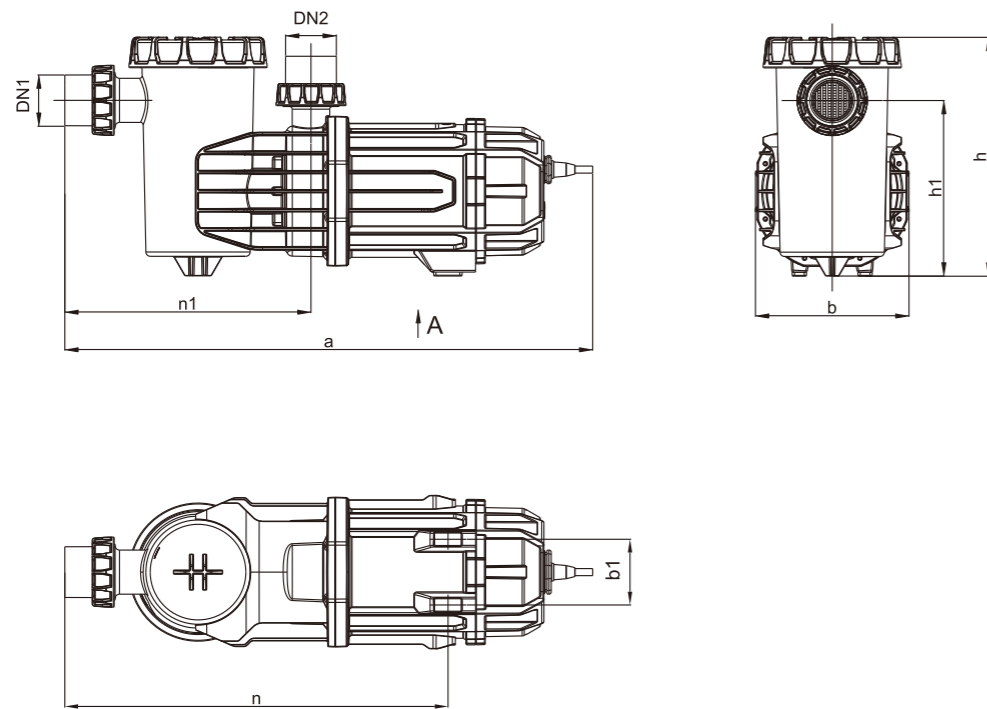

Model	DN1	DN2	Dimensions (mm)						
			a	b	b1	h	h1	n	n1
SPP25	57.5	57.5	598	174	74	271	199	434	279
SPP100	57.5	57.5	598	174	74	271	199	434	279
SPP25-BLE	57.5	57.5	598	174	74	271	199	434	279
SPP100-BLE	57.5	57.5	598	174	74	271	199	434	279

QDX-L1

Permanent Magnet Variable Frequency Submersible Pump

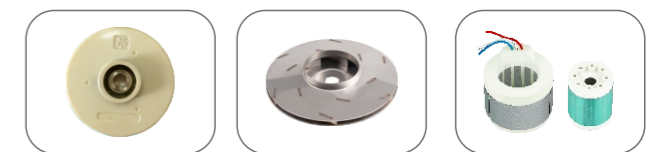

Features

- Multiple Patented Technologies
- Full-Head Operation Without Burnout
- Dry-Run Protection
- Automatic Interval Restart Detection
- Overheat Protection
- Wide Voltage Adaptation
- Compact & Lightweight
- High Flow Rate & High Head
- Comprehensive Safety Protection

Model Instruction

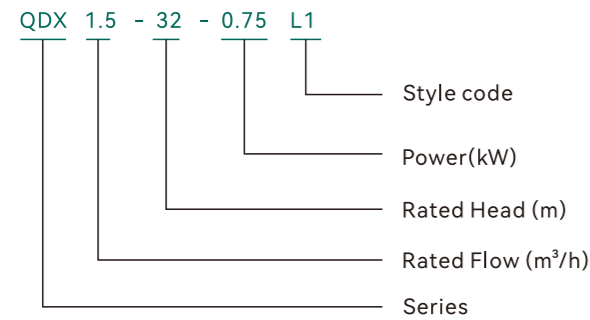

Agricultural irrigation



Working Conditions

Medium temperature	≤40°C
pH Value	6.5-8.5
Medium size	The volume content of solid particles shall not exceed 0.1%, with particle size not greater than 0.2 mm
Diving depth	≤5m

Performance Data

Model	QDX1.5-32-0.75L1	QDX8-18-0.75L1	QDX10-16-0.75L1
Power(W)	750	750	750
Max.Q(m³/h)	7.0	17	19
Rated.Q(m³/h)	1.5	8.0	10
Max.H(m)	34	22	21
Rated.H(m)	32	18	16
Speed(r/min)	5400	5400	5400
Current(A)	5.8	5.8	5.8
Voltage(V)	220	220	220
Frequency(Hz)	50/60	50/60	50/60
Outlet(mm)	25	40	50

Model	QDX15-10-0.75L1	QDX30-6-0.75L1
Power(W)	750	750
Max.Q(m³/h)	28	36
Rated.Q(m³/h)	15	30
Max.H(m)	12	10
Rated.H(m)	10	6
Speed(r/min)	5400	5400
Current(A)	5.8	5.8
Voltage(V)	220	220
Frequency(Hz)	50/60	50/60
Outlet(mm)	65	75

Performance Curve

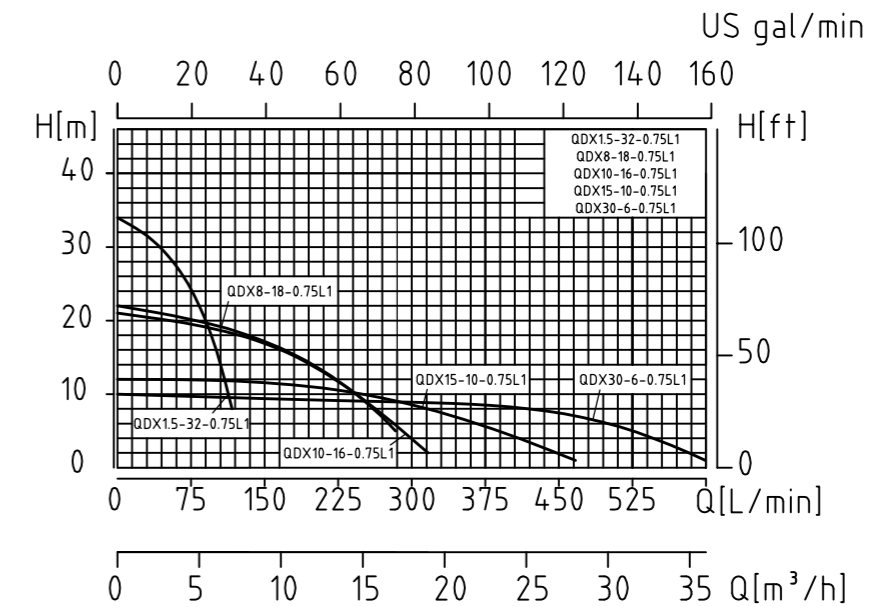

Installation Dimensions

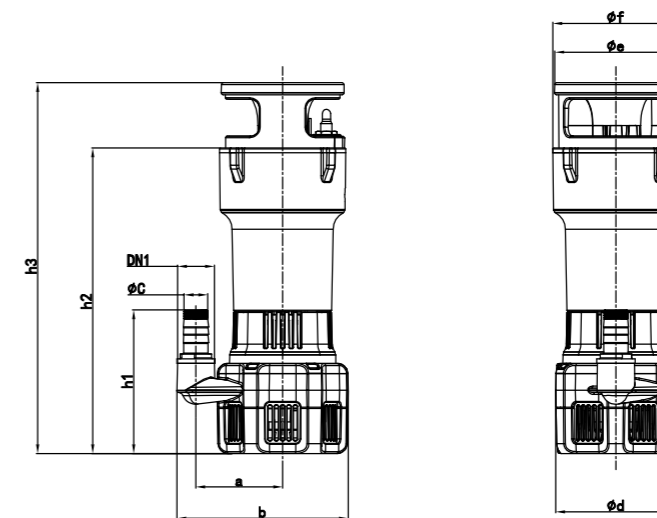

Model	DN1	φC	Dimensions (mm)							N.W. (kg)	G.W. (kg)	Carton size (mm)	
			a	b	φd	φe	φf	h1	h2				h3
QDX1.5-32-0.75L1	G1	25	93	184	129	132	136	154	328	398	7.6	8.3	452x262x227
QDX8-18-0.75L1	G2	40	123	228	129	132	136	177.5	344	414			
QDX10-16-0.75L1	G2	50	123	228	129	132	136	181.5	344	414			
QDX15-10-0.75L1	G2	65	123	230	129	132	136	181.5	344	414			
QDX30-6-0.75L1	G3	80	123	230	129	132	136	181.5	344	414			

QDX-S(F)

Permanent Magnet Variable Frequency Submersible Pump



QDX-S



QDX-SF



Features

- Multiple Patented Technologies
- Full-Head Operation Without Burnout
- Dry-Run Protection
- Automatic Interval Restart Detection
- Overheat Protection
- Wide Voltage Adaptation
- Compact & Lightweight
- High Flow Rate & High Head
- Comprehensive Safety Protection

Model Instruction

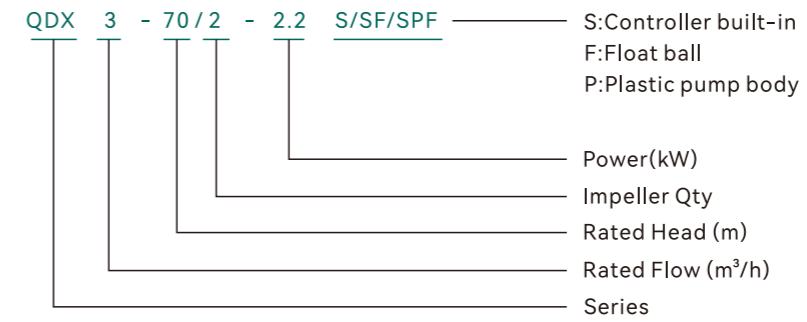

Agricultural irrigation



Working Conditions

Medium temperature	≤40°C
pH Value	6.5-8.5
Medium size	The volume content of solid particles shall not exceed 0.1%, with particle size not greater than 0.2 mm
Diving depth	≤5m

Performance Data				
Model	QDX1.5-45-1.1S	QDX10-20-1.1S	QDX3-70/2-2.2S	QDX10-38-2.2S
Power(W)	1100	1100	2200	2200
Max.Q(m³/h)	7.5	21	8.0	21
Rated.Q(m³/h)	1.5	10	3.0	10
Max.H(m)	51	27	75	41
Rated.H(m)	45	20	70	38
Speed(r/min)	5500	5500	5500	5500
Current(A)	5.8	5.8	9.3	9.3
Voltage(V)	220	220	220	220
Frequency(Hz)	50/60	50/60	50/60	50/60
Outlet(mm)	25	50	25	50

Model	QDX25-20-2.2S	QDX40-12-2.2S	QDX65-7-2.2S
Power(W)	2200	2200	2200
Max.Q(m³/h)	40	65	91
Rated.Q(m³/h)	25	40	65
Max.H(m)	28	22	13
Rated.H(m)	20	12	7
Speed(r/min)	5500	4000	4000
Current(A)	9.3	9.3	9.3
Voltage(V)	220	220	220
Frequency(Hz)	50/60	50/60	50/60
Outlet(mm)	65	80	100

Model	QDX1.5-45-1.1SF	QDX10-20-1.1SF	QDX3-70/2-2.2SF	QDX10-38-2.2SF
Power(W)	1100	1100	2200	2200
Max.Q(m³/h)	7.5	21	8.0	21
Rated.Q(m³/h)	1.5	10	3.0	10
Max.H(m)	51	27	75	41
Rated.H(m)	45	20	70	38
Speed(r/min)	5500	5500	5500	5500
Current(A)	5.8	5.8	9.3	9.3
Voltage(V)	220	220	220	220
Frequency(Hz)	50/60	50/60	50/60	50/60
Outlet(mm)	25	50	25	50

Model	QDX25-20-2.2SF	QDX40-12-2.2SF	QDX65-7-2.2SF
Power(W)	2200	2200	2200
Max.Q(m³/h)	40	65	91
Rated.Q(m³/h)	25	40	65
Max.H(m)	28	22	13
Rated.H(m)	20	12	7
Speed(r/min)	5500	4000	4000
Current(A)	9.3	9.3	9.3
Voltage(V)	220	220	220
Frequency(Hz)	50/60	50/60	50/60
Outlet(mm)	65	80	100

Performance Curve

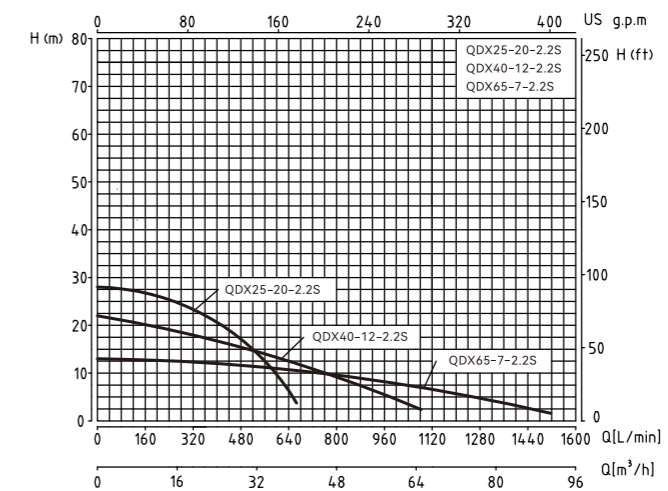
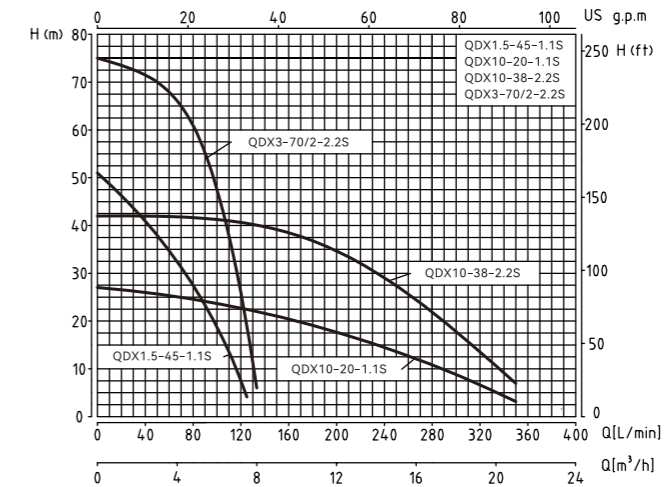

Installation Dimensions

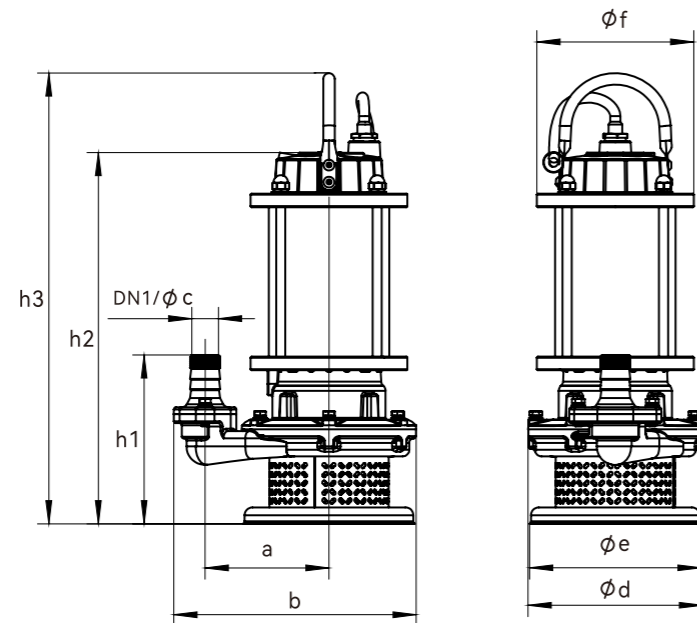

Model	DN1/φc	Dimensions (mm)								N.W. (kg)	G.W. (kg)	Carton size (mm)
		a	b	φd	φe	φf	h1	h2	h3			
QDX1.5-45-1.1SF	G¾/25	109	215	155	151	138	150	375	450	12.3	13.4	570x310x215
QDX10-20-1.1SF	G1½/50	123	236	155	151	138	187	398	473	12.9	14	570x310x215
QDX10-38-2.2SF	G1½/50	123	236	155	151	150	184	395	470	14.9	16	570x310x215
QDX3-70/2-2.2SF	G¾/25	109	215	155	151	150	211	437	511	16.6	17.7	570x310x215
QDX25-20-2.2SF	G2/65	130	252	158	151	150	209	409	483	15.8	16.9	570x310x215
QDX40-12-2.2SF	G2½/80	139	282	188	163	150	241	437	511	18.5	21.3	556x316x216
QDX65-7-2.2SF	G3/100	163	336	225	163	150	267	447	539	21.9	25.5	556x316x216
QDX1.5-45-1.1S	G¾/25	109	215	155	151	138	150	375	450	12	13.1	570x310x215
QDX10-20-1.1S	G1½/50	123	236	155	151	138	187	398	473	12.6	13.7	570x310x215
QDX10-38-2.2S	G1½/50	123	236	155	151	150	184	395	470	14.6	15.7	570x310x215
QDX3-70/2-2.2S	G¾/25	109	215	155	151	150	211	437	511	16.3	17.4	570x310x215
QDX25-20-2.2S	G2/65	130	252	158	151	150	209	409	483	15.5	16.6	570x310x215
QDX40-12-2.2S	G2½/80	139	282	188	163	150	241	437	511	18.2	21	556x316x216
QDX65-7-2.2S	G3/100	163	336	225	163	150	267	447	539	21.6	25.2	556x316x216

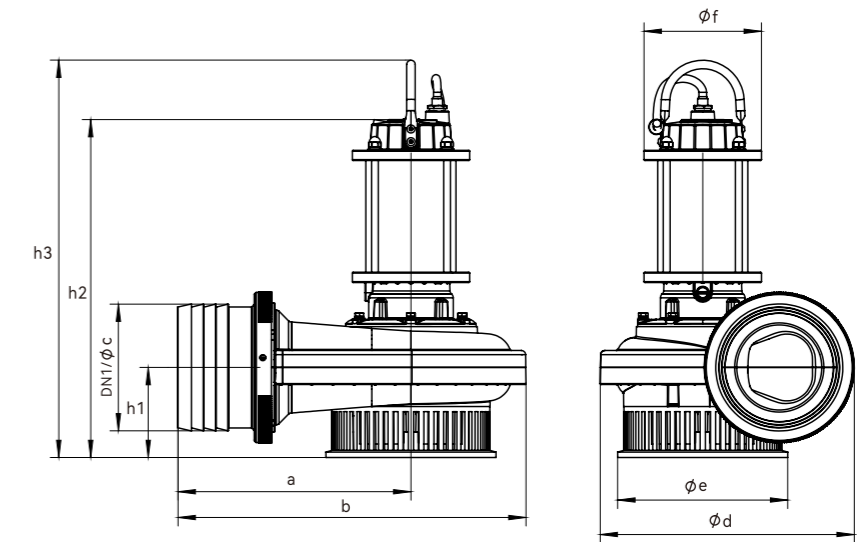

Model	DN1/φc	Dimensions (mm)							
		a	b	φd	φe	φf	h1	h2	h3
QDX65-7-2.2SPF	G4/100	275	410	299	200	150	106	445	519
QDX80-5-2.2SPF	G6/150	275	410	299	200	150	106	445	519
QDX65-7-2.2SP	G4/100	275	410	299	200	150	106	445	519
QDX80-5-2.2SP	G6/150	275	410	299	200	150	106	445	519

WQ(D)-DC

Permanent Magnet Variable Frequency Submersible Sewage Pump



WQD



WQ



Features

- Multiple Patented Technologies
- Full-Head Operation Without Burnout
- Dry-Run Protection
- Automatic Interval Restart Detection
- Overheat Protection
- Wide Voltage Adaptation
- Compact & Lightweight
- High Flow Rate & High Head
- Comprehensive Safety Protection

Model Instruction

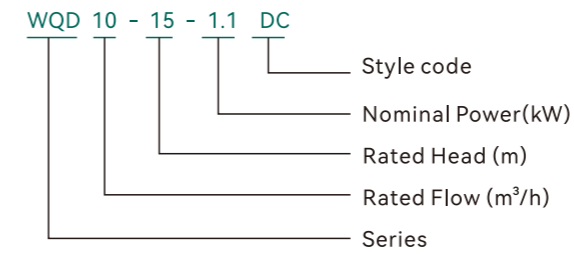

Agricultural irrigation



Working Conditions

Medium temperature	≤40°C
pH Value	4-10
Diving depth	≤5m

Performance Data

Model	WQD10-15-1.1DC	WQD10-25-2.2DC
Power(W)	1100	2200
Max.Q(m³/h)	24	33
Rated.Q(m³/h)	10	10
Max.H(m)	24	31
Rated.H(m)	15	25
Speed(r/min)	4200	4200
Current(A)	6.2	9.5
Voltage(V)	220	220
Frequency(Hz)	50/60	50/60
Outlet(mm)	50	50

Model	WQ15-30-3DC	WQ25-22-3DC	WQ40-18-3DC
Power(W)	3000	3000	3000
Max.Q(m³/h)	36	36	
Rated.Q(m³/h)	15	25	40
Max.H(m)	38	38	
Rated.H(m)	30	22	18
Speed(r/min)	4000	4000	4000
Current(A)	6.5		
Voltage(V)	380	380	380
Frequency(Hz)	50/60	50/60	50/60
Outlet(mm)	50	65	80

Performance Curve

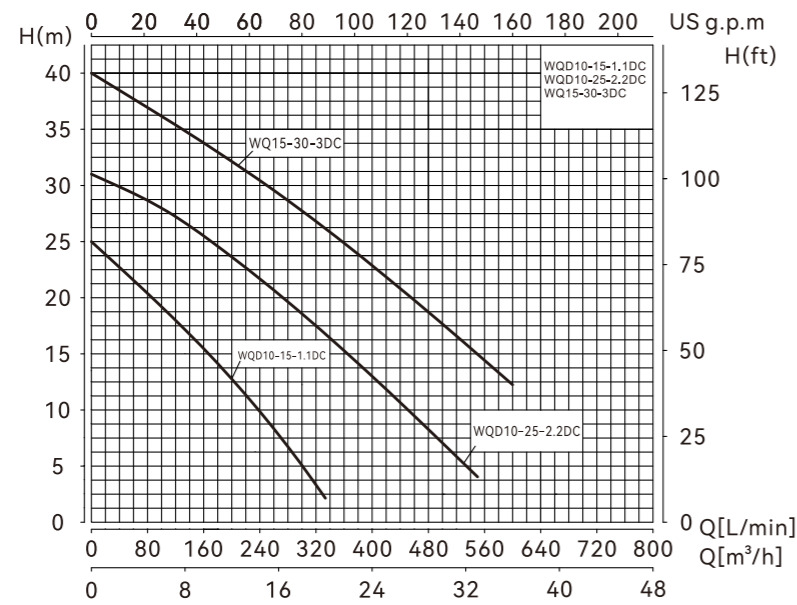

Installation Dimensions

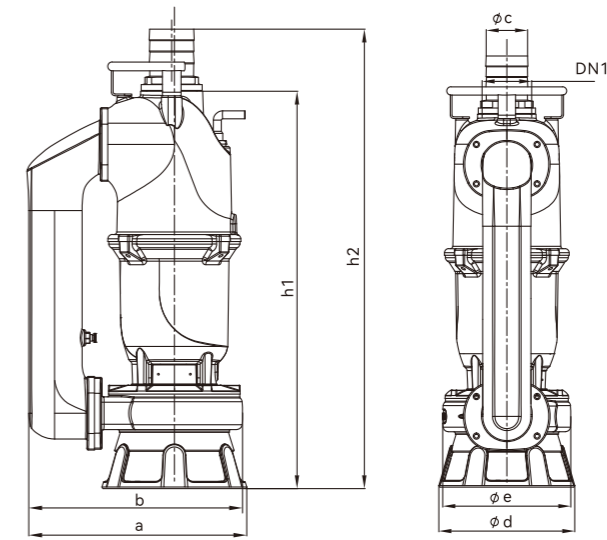

Model	DN1	Dimensions (mm)							Carton size (mm)
		a	b	φc	φd	φe	h1	h2	
WQD10-15-1.1DC	G2	245	241	50	165	154	448	518	576x291x196
WQD10-25-2.2DC	G2	245	251	50	165	177	460	530	576x291x196

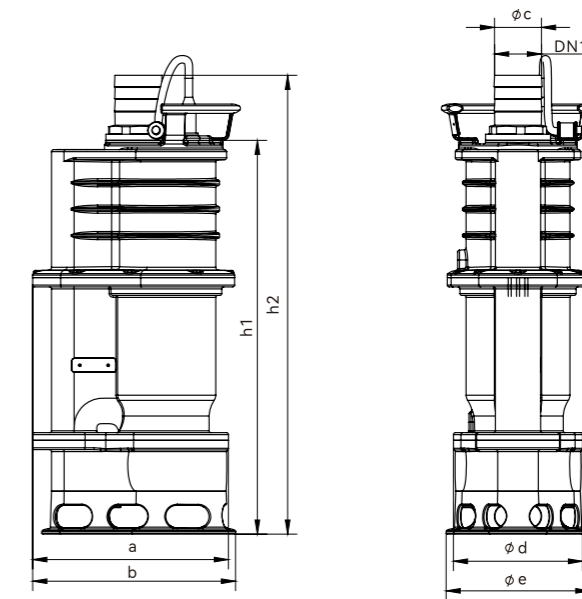

Model	DN1	Dimensions (mm)							Carton size (mm)
		a	b	φc	φd	φe	h1	h2	
WQD10-10-0.75DCB	G2	215	207	50	162	137	417	486	
WQD10-15-1.1DCB	G2	215	207	50	162	137	417	486	
WQ15-30-3DC	G2	296	302	50	200	213	478	553	586x336x356

WQ-DCS

Permanent Magnet Variable Frequency Submersible Sewage Pump



Features

- Multiple Patented Technologies
- Full-Head Operation Without Burnout
- Dry-Run Protection
- Automatic Interval Restart Detection
- Overheat Protection
- Wide Voltage Adaptation
- Compact & Lightweight
- High Flow Rate & High Head
- Comprehensive Safety Protection
- APP function
- Parallel function

Model Instruction



Agricultural irrigation



Working Conditions

Medium temperature	≤40°C
pH Value	4-10
Diving depth	≤5m

Performance Data

Model	WQ20-42-7.5DCS	WQ30-32-7.5DCS	WQ45-30-7.5DCS
Power(W)	7500	7500	7500
Max.Q(m³/h)	58	83	90
Rated.Q(m³/h)	20	30	45
Max.H(m)	48	38	37
Rated.H(m)	42	32	30
Speed(r/min)	3600	3600	3600
Current(A)	16	16	16
Voltage(V)	380	380	380
Frequency(Hz)	50/60	50/60	50/60
Outlet(mm)	50	65	80
Multi-Pump	●	●	●
WiFi	●	●	●

Model	WQ80-15-7.5DCS	WQ100-12-7.5DCS
Power(W)	7500	7500
Max.Q(m³/h)	124	165
Rated.Q(m³/h)	80	100
Max.H(m)	25	20
Rated.H(m)	15	12
Speed(r/min)	3600	3600
Current(A)	16	16
Voltage(V)	380	380
Frequency(Hz)	50/60	50/60
Outlet(mm)	100	150
Multi-Pump	●	●
WiFi	●	●

Installation Dimensions

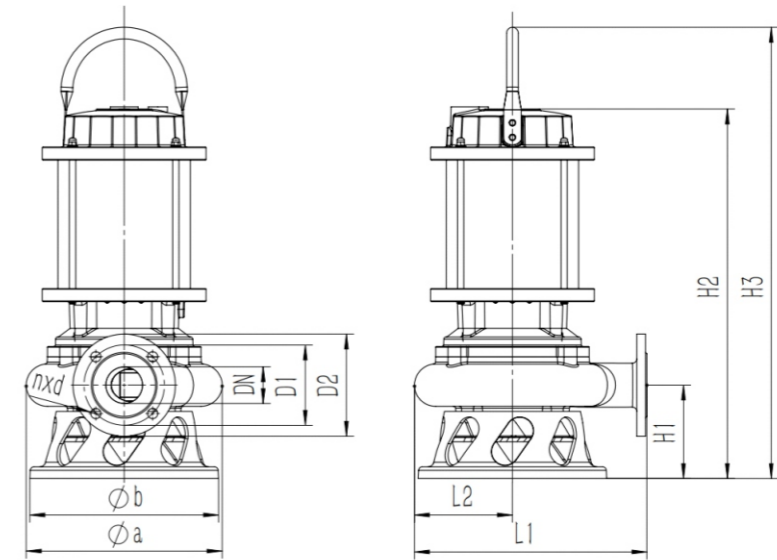

Performance Curve

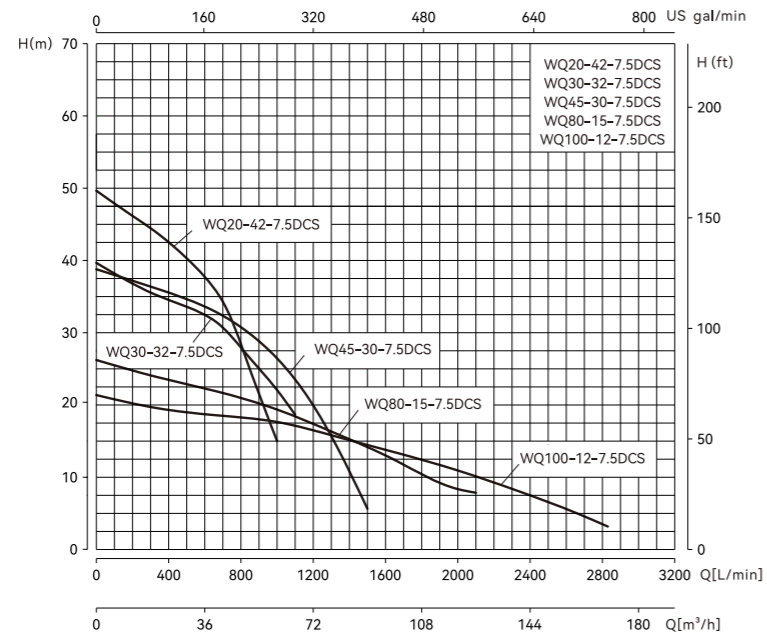

Model	Dimensions (mm)					Flange (mm)				N.W.		
	L1	L2	H1	H2	H3	a	b	DN	D1		D2	n*d
WQ20-42-7.5DCS	320	130	130	510	645	260	258	50	Ø110	Ø140	4* Ø14	47.1
WQ30-32-7.5DCS	320	138	138	521	656	277	258	65	Ø130	Ø160	4* Ø14	48
WQ45-30-7.5DCS	300	115	130	521	656	230	258	80	Ø150	Ø190	4* Ø18	47.1
WQ80-15-7.5DCS	370	145	140	542	677	290	258	100	Ø170	Ø210	4* Ø18	50.7
WQ100-12-7.5DCS	375	155	154	555	690	310	258	150	Ø225	Ø265	4* Ø18	54.4

PLD/PLDM/PLDS/SLS

Intelligent Inverter Pump Controller



PLD



PLDM/PLDS



PLDS-2S-2.5



SLS/SLM

Features

- ⦿ Constant pressure
- ⦿ Energy conservation
- ⦿ Multi-protection
- ⦿ Frost protection
- ⦿ Compact and lightweight
- ⦿ Periodic water replenishment
- ⦿ Wide voltage
- ⦿ APP function
- ⦿ Parallel function

Model Instruction

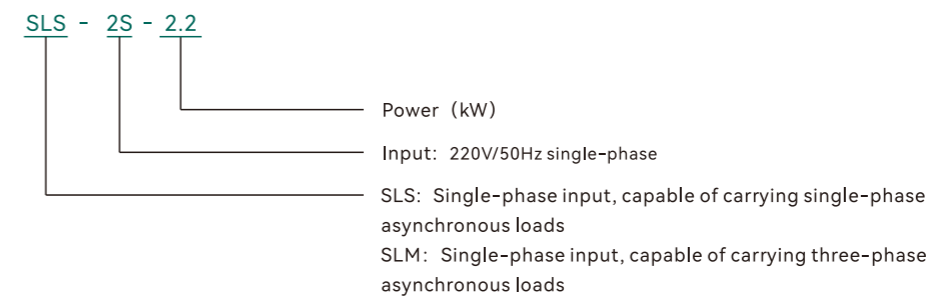
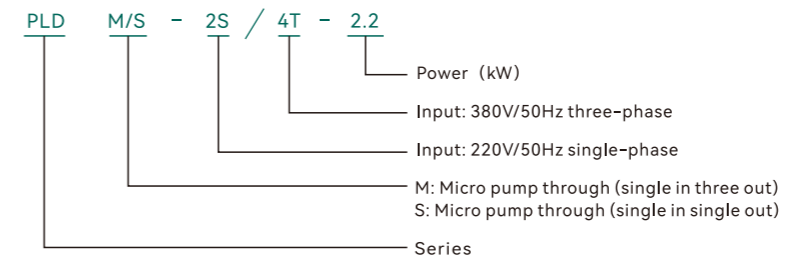

Performance Data

Model	PLDM-2S-2.2	PLD-2S-2.2	PLD-4T-2.2	PLD-4T-4
Power(W)	2200	2200	2200	4000
Current(A)	≤10.5	≤10.5	≤5.7	≤9.0
Power input (V)	220	220	380	380
Controller output(V)	3PH 220	380	380	380
Multi-P	●	●	●	●
WiFi	●	●	●	●

Model	PLD-4T-5.5	PLD-4T-7.5	PLDS-2S-2.2	PLDS-2S-2.4
Power(W)	5500	7500	2200	2200
Current(A)	≤13	≤17	≤10.5	≤17
Power input (V)	380	380	220	220
Controller output(V)	380	380	220	220
Multi-P	●	●	●	●
WiFi	●	●	●	●

Model	PLDS-2S-2.5	SLS-2S-2.2	SLM-2S-2.2
Power(W)	2200	2200	2200
Current(A)	≤15.5	≤15.5	≤15.5
Power input (V)	220	220	220
Controller output(V)	220	220	3PH 220
Multi-P	●	●	●
WiFi	●	●	●

Installation Dimensions

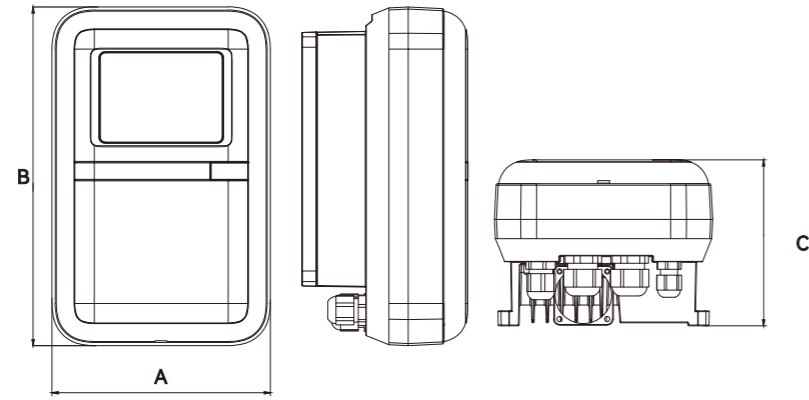

	A	B	C	Carton size (mm)	
PLD	0.75-2.2kW	14.7cm	22.8cm	11cm	265x250x160
	4-7.5kW	15.7cm	24.4cm	12.6cm	290x285x170
	11-18.5kW	20.7cm	32.2cm	15cm	
PLDS-2S-2.4	14.7cm	22.8cm	11cm	265x250x160	

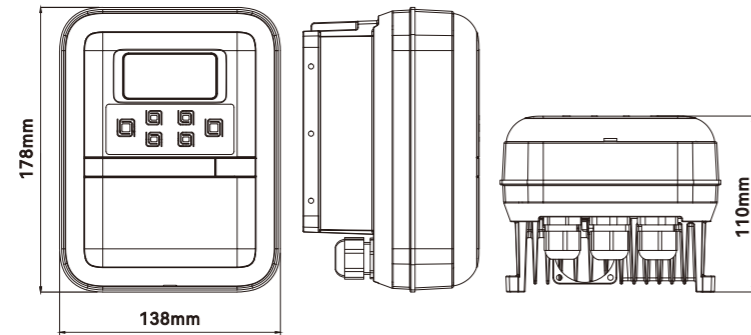

Model	Carton size (mm)
PLDM-2S-2.2	270x215x170
PLDS-2S-2.2	270x215x170

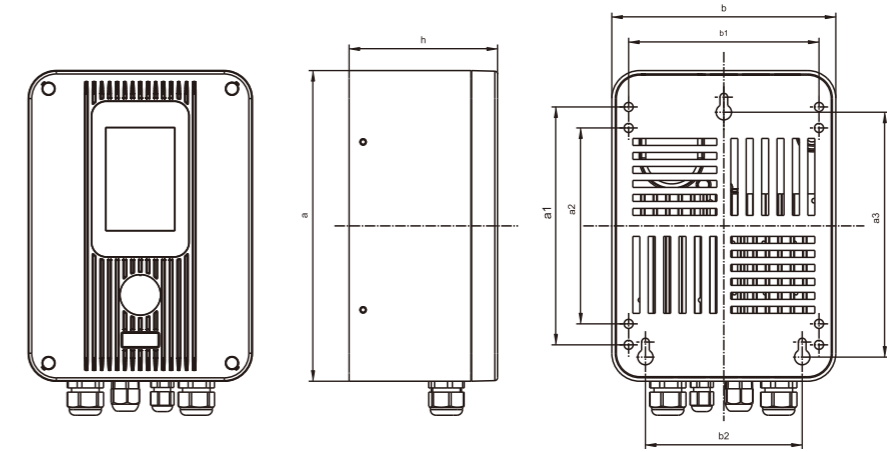

Model	Dimensions (mm)							
	a	a1	a2	a3	b	b1	b2	h
PLDS-2S-2.5	222	170	140	175	160	136	112	106
WQD-QDX-ES	222	170	140	175	160	136	112	106

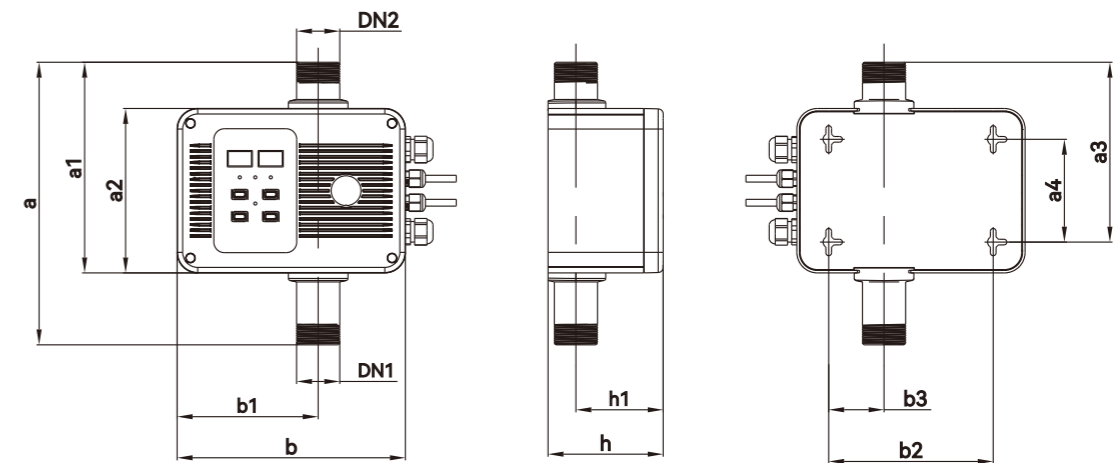

Model	DN1	DN2	Dimensions (mm)											Carton size (mm)
			a	a1	a2	a3	a4	b	b1	b2	b3	h	h1	
SLM-2S-2.2	G1¼	G1¼	275	205	160	175	100	222	137	160	54	112	85	325x150x310
SLS-2S-2.2	G1¼	G1¼	275	205	160	175	100	222	137	160	54	112	85	325x150x310